



ODISHA POWER TRANSMISSION CORPORATION LTD.

(A Government of Odisha Undertaking)

CIN – U40102OR2004SGC007553

REGD. OFFICE: JANPATH, BHUBANESWAR – 751022,

OFFICE OF THE GENERAL MANAGER (Elect)

EHT (O&M) Circle, Cuttack. At :- Madhusudan Nagar

P.O:- Tulsipur, Cuttack-753008.

Tel-/FAX-(0671)-2300547, E-mail-ehm.cle.ctc@optcl.co.in

TENDER SPECIFICATION NO:- ETCN/01/CTC/2017-18

FOR

SUPPLY OF PERFORATED TYPE ALUMINIUM CABLE TRAYS, BENDS, CENTRAL REDUCERS AND TEES OF DIFFERENT SIZES WITH BLACK POWDER COATING ALONG WITH REQUIRED SIDE COUPLER PLATES AND HARDWARES FOR 132/33KV GRID SUB-STATION, KENDRAPARA

PART-I

SECTION-I: INSTRUCTION TO TENDERERS.

SECTION-II: GENERAL CONDITIONS OF CONTRACT

SECTION-III: LIST OF ANNEXURES

SECTION-IV: TECHNICAL SPECIFICATIONS & OTHER DATA SHEET

PART II

PRICE BID & TECHNO COMMERCIAL BID (IN EXCEL FORMAT)

Request for online tender documents: From dt- 05.06.2017 (10.00 Hrs) to dt-19.06.2017 (12.30 Hrs)

Issue of online tender documents: From dt- 05.06.2017 (10.01 Hrs) to dt-19.06.2017 (12.31 Hrs)

(Bid sheets)

Last date of submission of online tender: Up to dt-19.06.2017 (17.00 Hrs)

Date of opening of Technocommercial Bid: On dt- 20.06.2017 (16.30 Hrs) On wards

Date of Opening of Price Bid: To be intimated after Sample Selection

TELEPHONES / CONTACTS

1. General Manager: 09438907551
2. TA to General Manager: 9438907673
3. Office Land Line: 0671-2300226 / 2307386

NOTE: -

1. In case the due date for opening of tender happens to be a holiday, then tenders would be received & opened on the next working day at the same time.
2. Please note that the tenders against this tender enquiry are being invited **through e-tendering mode**. In case of any clarification the prospective bidders may contact this office as mentioned above.
3. **The prospective bidders are requested to get their digital signatures (Class-3) well in time** for participation in the tender and no request for extension on this account will be entertained.
4. **Manual tenders in any form/case will not be accepted.**



ODISHA POWER TRANSMISSION CORPORATION LTD.

(A Government of Odisha Undertaking)

CIN – U40102OR2004SGC007553

REGD. OFFICE: JANPATH, BHUBANESWAR – 751022,

OFFICE OF THE GENERAL MANAGER, (Elect)

EHT (O&M) Circle, Cuttack. At :- Madhusudan Nagar

P.O:- Tulsipur, Cuttack-753008.

Tel- 0671-2300226 / 0671-2307386, E-mail-ehm.cle.ctc@optcl.co.in

E-TENDER NOTICE NO. 01/CTC/2017-18

For and on behalf of ODISHA POWER TRANSMISSION CORPORATION LTD, General Manager, EHT (O&M) Circle, Cuttack, invites Tenders from Reputed manufacturers /Experienced suppliers /Authorized Dealers in two part bidding system for **SUPPLY OF PERFORATED TYPE ALUMINIUM CABLE TRAYS, BENDS, CENTRAL REDUCERS AND TEES OF DIFFERENT SIZES WITH BLACK POWDER COATING ALONG WITH REQUIRED SIDE COUPLER PLATES AND HARDWARES FOR 132/33KV GRID SUB-STATION, KENDRAPARA.**

The interested bidders would be required to enroll themselves on the tender portal www.tenderwizard.com/OPTCL and must possess Class 3 Digital Signature Certificate. Complete set of bidding documents are available at www.tenderwizard.com/OPTCL from **05.06.2017 (10.00 Hrs) to dt- 19.06.2017 (12.30 Hrs)**. Interested bidders may visit OPTCL's official web site <http://www.optcl.co.in> and www.tenderwizard.com/OPTCL for detail specification.

N.B:- All subsequent addendums/corrigendum to the tender shall be hosted in the OPTCL's official web site <http://www.optcl.co.in> and www.tenderwizard.com/OPTCL only.

**GENERAL MANAGER
EHT (O&M) CIRCLE, CUTTACK**



ODISHA POWER TRANSMISSION CORPORATION LTD.,
CIN – U40102OR2004SGC007553
REGD. OFFICE: JANPATH, BHUBANESWAR – 751 022,
OFFICE OF THE GENERAL MANAGER, (Elect)
EHT (O&M) Circle, Cuttack. At :- Madhusudan Nagar
P.O:- Tulsipur, Cuttack-753008.

Tel- 0671-2300226 FAX-0671-2300547, E-mail-ehm.cle.ctc@optcl.co.in

NOTICE INVITING TENDER

E-TENDER NOTICE NO- 02/CTC/2017-18.

For and on behalf of the **ODISHA POWER TRANSMISSION CORPORATION LTD,** the undersigned invites bids **under two-part bidding system** in e- tendering mode only as per the following details.

Tender Specification No: EHTM/GM/02/CTC/2017-18

<i>Request for online tender documents –</i>	From dt 05.06.2017 (10.00 Hrs)
	To dt 19.06.2017 (12.30 Hrs)
<i>Issue of online tender documents (bid sheets)-</i>	From dt 05.06.2017 (10.01 Hrs)
	To dt 19.06.2017 (12.31 Hrs)
<i>Last date of submission of online tender–</i>	up to dt 19.06.2017 (17.00 Hrs)
<i>Date of opening of Tender-</i>	On dt 20.06.2017 (15.00 Hrs) onwards
<i>Cost of Tender Spec. Document: Rs.6000/ + Rs300/- (VAT) = Rs 6,300/-</i>	
<i>Earnest Money Deposit: Rs 22000/-</i>	
<i>Tender Processing Fee: Rs.2200/- + Rs 330/- (ST @ 15%) = Rs 2530/-</i>	

The bidders can view the tender documents from website free of cost. The bidders who want to participate in the tender shall have to pay **Rs6300/- (Rupees Six thousand three hundred only) non refundable** including VAT @ 5%) towards the cost of tender document, in the form of Demand draft only, drawn in favour of **EHT (O&M) Circle, OPTCL, Cuttack, Payable at Cuttack** and the same is to be submitted to the office of the undersigned on or before the last date & time of submission of tender.

The bidders shall have to submit a non refundable amount of Rs 2530/- (Rupees Two thousand five hundred and thirty only) towards the tender processing fee through e-payment gate way.

(NOTE: For deposit of tender processing fee to K.S.E.D.C. Ltd. Bangalore, the bidder can use various modes of e-payment facility available through Tender wizard Portal, i.e. by Credit Card, Debit Card, Net Banking)

The payment acknowledgement slip submitted along with the EMD & tender cost at the office of the undersigned on or before the last date & time of submission of tender.

The bidders shall scan the Demand Draft towards EMD, Tender paper Cost and acknowledgement slip for tender processing fee and upload the same in the prescribed form in **.gif** or **.jpg** format in addition to sending the original as stated above.

The prospective bidders are advised to register their user ID, Password, company ID from website www.tenderwizard.com/OPTCL by clicking on hyper link “Register Me”.

Any clarifications regarding the scope of work and technical features of the tender can be had from the undersigned during office hours.

GENERAL MANAGER
EHT (O&M) CIRCLE, CUTTACK

PART-I
SECTION-I
INSTRUCTIONS TO TENDERER

1. Submission of Bids: -

The bidder shall submit the bid in Electronic Mode only i.e www.tenderwizard.com/OPTCL. The bidder must ensure that the bids are received in the specified website of the OPTCL by the date and time indicated in the Tender notice. Bids submitted by telex/telegram will not be accepted. No request to collect the Bids in physical form will be entertained by the OPTCL.

OPTCL reserves the right to reject any bid, which is not submitted according to the instruction, stipulated above. The participants to the tender should be registered under ODISHA Sales Tax Act, VAT Act / Central sales Tax Act.

1. For all the users it is mandatory to procure the Class 3 Digital Signatures.

2. Manufacturers / Dealers / Bidders / Suppliers are requested to follow the below steps for Registration:
 - a. Click “Register”, fill the online registration form.
 - b. Pay the amount of **Rs. 2300/-** through **E-payment gateway**.
 - c. This registration is valid for one year.
 - d. Send the acknowledgment copy for verification.
 - e. As soon as the verification is being done the e-tender user id will be enabled.
3. After viewing Tender Notification, if bidder intends to participate in tender, he has to use his e-tendering User Id and Password which has been received after registration and acquisition of DSCs.
4. If any Bidder wants to participate in the tender he will have to follow the instructions given below:
 - a. Insert the PKI (which consist of your Digital Signature Certificate – Class 3) in your System. (Note: Make sure that necessary software of PKI be installed in your system).
 - b. Click / Double Click to open the Microsoft Internet Explorer (This icon will be located on the Desktop of the computer).
 - c. Go to Start > Programs > Internet Explorer.
 - d. Type www.tenderwizard.com/OPTCL in the address bar, to access the Login Screen.
 - e. Enter e-tender User Id and Password, click on “Go”.
 - f. Click on “Click here to login” for selecting the Digital Signature Certificate.
 - Select the Certificate and enter DSC Password.
 - Re-enter the e-Procurement User Id Password

5. To make a request for Tender Document, Bidders will have to follow below mentioned steps.
 - a) Click “Un Applied” to view / apply for new tenders.
 - b) Click on Request icon for online request.
 - c) Enter the required fields including details of D.D for tender Processing fee.
6. After making the request Bidders will receive the Bid Documents which can be checked and downloaded by following the below steps:
 - a) Click to view the tender documents which are received by the user.
 - b) Tender document screen appears.
 - c) Click “Click here to download” to download the documents.
7. After completing all the formalities Bidders will have to submit the tender and they must take care of following instructions.
 - a) Prior to submission, verify whether all the required documents have been attached and uploaded to the particular tender or not.
 - b) Note down / take a print of bid control number once it displayed on the screen
8. Tender Opening event can be viewed online.
9. Competitors bid sheets are available in the website for all.
10. **For any e-tendering assistance contact help desk number mentioned below.**
 - **Bangalore – 080-40482000.**
 - **Mr. Satamanyu – mob: 09937140591**

2. Division of Specification.

The specification is mainly divided into two parts viz. Part-I & Part-II.

Part-I Consists of

SECTION-I- INSTRUCTION TO TENDERERS.

SECTION-II- GENERAL CONDITIONS OF CONTRACT

SECTION-III- LIST OF ANNEXURES

SECTION-IV- TECHNICAL SPECIFICATION AND OTHER DATASHEET.

Part-II Consists of

1) PRICE BID (Excel Sheet)

2) TECHNO COMMERCIAL BID (excel sheet)

The Tenderers are required to submit the tenders in two parts viz. Part-I (Techno commercial) & Part-II (Price bid).

3. Purchaser’s Right Regarding Alteration of Quantities Tendered.

The Purchaser may alter the quantities of materials / equipment at the time of placing orders.

Initially the purchaser may place orders for lesser quantity with full freedom to place extension

orders for further quantity under similar terms and conditions of the original orders. Orders may also be split among more than one tenderer for any particular item, if considered necessary in the interest of the Purchaser to get the goods/equipment earlier.

4. Purchaser's right to accept / reject bids:

The purchaser reserves the right to reject any or all the tenders without assigning any reasons what so ever if it is in the interest of OPTCL, under the then circumstances

5. Mode of submission of Tenders.

[A] Tenders shall be submitted in electronic mode only. (www.tenderwizard.com/OPTCL)

[B] **Telegraphic or FAX tenders** shall not be accepted under any circumstances.

6. Earnest money deposit:

The tender shall be accompanied by Earnest Money deposit of value specified in the notice inviting tenders against each bid. Tenders without the required EMD will be rejected out rightly.

The earnest money deposit shall be furnished in shape of **Bank Draft (Only)**:-To be drawn in favour of **EHT (O&M) Circle, OPTCL, Cuttack, Payable at Cuttack.**

NOTE:-

- a) No adjustment towards EMD shall be permitted against any outstanding amount with the **ODISHA POWER TRANSMISSION CORPORATION LTD.**
- b) In the case of un-successful tenderer, the EMD will be refunded on written request without any interest after the tender is decided. In the case of successful Tenderer, this will be refunded only after furnishing of the security money.
- c) Suits, if any, arising out of this clause shall be filed in a Court of law to which the jurisdiction of High Court of ODISHA extends.
- d) EMD will be forfeited if the tenderer fails to accept the letter of intent and /or purchase order issued in his favour or to execute the order, placed on them.
- e) Tenders not accompanied by Earnest Money shall be disqualified.
- f) EMD carries no interest.
- g) **The EMD not claimed for refund within a period of one year from the date of issue of Purchase/ Work orders and the Security Deposit not claimed for refund within a period of three years after completion of contract, will be forfeited.**

7. Validity of the Bids: -

The tenders should be kept valid for a period of **180** days from the date of opening of the tender, failing which the tenders will be rejected.

8. PRICE: -

The bidders are advised to quote their rate as per the price schedule and shall remain firm inclusive of all taxes & duties, labour charges etc. within the validity of the tender

9. Tenderers to be fully conversant with the clauses of the Specification:

Tenderers are expected to be fully conversant with the meaning of all the clauses of the specification before submitting their tenders. In case of doubt regarding the meaning of any clause, the tenderer may seek clarification in writing from the **GM EHT (O&M) Circle, Cuttack**. This however does not entitle the tenderer to ask for time beyond due date, fixed for receipt of tender.

10. Documents to Accompany Bids.

- a) Tenderers are required to submit tenders in the following manner:
- b) Declaration Form as per **Annexure-I** (duly signed) to be uploaded in ***.pdf** format.
- c) Earnest Money (scanned copy is to be uploaded)
- d) Abstract of Terms & conditions in prescribed proforma as per **Annexure-II**. To be keyed in the bid sheets provided.
- e) General Terms & Conditions of contract as per Section-II of the Specification. (All the required documents are to be uploaded.)
- f) Data on past experience if any **as per** the Specification.(Scanned copy to be uploaded)
- g) Proof of Manufacturer, Supplier, Authorised dealer, permanent account number [PAN] of the firm is required under Income tax Act. (Scanned copy to be uploaded).
- h) Any other document required, is to be uploaded.
- i) Schedule of prices in the prescribed proforma in the price bid sheet provided in ***.xls** format.
- j) Photostat copies of type test certificates of materials/equipments offered as stipulated in the Technical Specification

11. Conditional Offer:

Conditional offer shall not be accepted.

12. General Instruction to the Tenderers : -

- i) The tenderer must get him registered in tender portal by paying an amount of **Rs. 2300/- through e-payment gate way**. This registration is valid for one year.
- ii) The tender paper cost (Form fee non refundable) for an amount of **Rs 6300/- to be deposited in shape of DD**.
- iii) The tender processing fee for an amount of **Rs 2530/-(Non-refundable) is to be paid to KSEDC Limited, Bangalore through e-payment gateway**.
- iv) The EMD amount as specified is to be paid in shape of DD.
- v) In the event of discrepancy or arithmetical error in the schedule of price, the decision of the purchaser shall be final and binding on the Tenderer.
- vi) Notice inviting tender shall form part of this specification.

- vii) The EMD shall be returned to the unsuccessful bidders after finalization of tender on written request.
- viii) It should be distinctly understood that the price bid and techno-commercial bid shall contain only details / documents relating to price and technical details, as mentioned herein above.
- ix) **The Tenderer must submit the EMD amount, cost of tender document in shape of draft and proof of Tender processing fee in a sealed cover envelope super scribing the Tender Notice No & Date of opening of tender. The said envelope is to be submitted in the office of the purchaser on or before the last date and time of submission of tender.**

PART-I

SECTION-II

GENERAL TERMS AND CONDITIONS OF CONTRACT [G.T.C.C.]

1. Scope of the contract:

This specification covers “**Supply of Perforated type Aluminium Cable Trays, bends, central reducers and tees of different sizes with black powder coating along with required side coupler plates and hardwares for 132/33KV Grid Sub-station, Kendrapara as per specification**” as per technical requirement mentioned in Section – IV of the tender specification. The scope of contract shall be to deliver the material on Rail/Road transport at destinations of OPTCL site store as specified in the schedule of quantity. **The tenderer should quote the make of items and indicate whether the materials bear ISI mark. The bids must be accompanied with necessary test certificates. In case of non-manufacturers, the bidders have to submit authorization certificate from cable tray manufacturers, without which their tenders will not be entertained**

2. Definition of terms:

For the purpose of this specification and General Terms and Conditions of contract [GTCC], the following words shall have the meanings hereby indicated, except where otherwise described or defined.

- 2.1 “The Purchaser” shall mean the General Manager, EHT (O&M) Circle, Cuttack for and on behalf of ODISHA POWER TRANSMISSION CORPORATION LTD., Bhubaneswar.
- 2.2 “The Engineer” shall mean the Engineer appointed by the Purchaser for the purpose of this contract.
- 2.3 “Purchaser’s Representative” shall mean any person or persons or consulting firm appointed and remunerated by the Purchaser to supervise, inspect, test and examine workmanship and materials of the equipment to be supplied.
- 2.4 “The supplier” shall mean the bidder whose bid has been accepted by the purchaser and shall include the bidder’s executives, administrators, successors and permitted assignees.
- 2.5 “Equipment” shall mean and include all machinery, apparatus, materials, and articles to be provided under the contract by the suppliers.
- 2.6 “Contract Price” shall mean the sum named in or calculated the bid.
- 2.7 “General Condition” shall mean these General Terms and Conditions of Contract.
- 2.8 “The Specification” shall mean both the technical as well as commercial parts of the specification annexed to or issued with GTCC and shall include the **schedules** and drawings, attached thereto as well as all samples and pattern, if any.
- 2.9 “Month” shall mean “Calendar month”.

- 2.10 “Writing” shall include any manuscript, type written, printed or other statement reproduction in any visible form and whether under seal or under hand.
- 2.11 “FOR Destination costs” shall mean the cost of equipment and material at the consignee’s store/site. The cost is inclusive of Excise duty, Sales tax and other local taxes, packing, forwarding and insurance and freight charges.
- 2.12 The term “Contract document” shall mean and include GTCC, specifications, schedules, drawings, form of tender, Notice Inviting Tender, covering letter, schedule of prices or the final General Conditions, any special conditions, applicable to the particular contract.
- 2.13 Terms and conditions not herein defined shall have the same meaning as are assigned to them in the Indian Contract Act, failing that in the ODISHA General Clauses Act.

3. Manner of execution:

All materials supplied under the contract shall conform to the relevant IS and shall be manufactured in the manner, set out in the specification or where not set out, to the reasonable satisfaction of the Purchaser.

4. GENERAL REQUIREMENT:

The cable trays must be suitable for the purpose of carrying control cables of various sizes from the switchyard to the control room. The cable tray accessories like couplers, clamps and nuts and bolts must also be included in the quotation. The trays and its accessories should conform to the relevant Indian Standards.

- 5. SUBMISSION OF SAMPLE: The bidders are requested to submit the sample of cable trays and other accessories along with test certificates from Govt. approved laboratory to this office on or before tender opening date.** The samples of all bidders shall be scrutinized by a sample scrutiny committee to be constituted by the purchaser. If required, the bidder or their authorized representatives may be informed to remain present during scrutiny of samples. The date of sample scrutiny will be intimated to the bidders in due course. The bidders, whose samples are approved by the committee, shall be considered for price comparison. *In no case, the bidders shall be allowed for change of sample.*

6. Rejection of Materials.

In the event any of the equipments /material supplied by the manufacturer is found defective due to faulty design, bad workmanship, bad materials used or otherwise not in conformity with the requirements of the Specification, the Purchaser shall either reject the equipment /material or ask the supplier in writing to rectify or replace the defective equipment / material free of cost to the purchaser. The Supplier on receipt of such notification shall either rectify or replace the defective equipment /material free of cost to the purchaser within 15 days from the date of issue of such notification by the purchaser.

7. **Language and measures:**

All documents pertaining to the contract including specifications, schedule, notices, correspondence, operating and maintenance instructions, drawings or any other writing shall be written in English language. The metric system of measurement shall be used exclusively in this contract.

8. **Right to reject /accept any tender:**

The purchaser reserves the right either to reject or to accept any or all tenders if the situation so warrants in the interest of the purchaser. Orders may also be split up between different Tenderers on individual merits of the Tenderer. The purchaser has exclusive right to alter the quantities of materials/ equipment at the time of placing final purchase order. After placing of the order, the purchaser may defer the delivery schedule of the materials. It may be clearly understood by the Tenderer that the purchaser need not assign any reason for any of the above action[s].

9. **Delivery:-**

The desired delivery period shall be within 30 (sixty) days of placing purchase order.

10. **Despatch instructions.**

a) The equipments/ materials should be securely packed and dispatched directly to the specified site at the supplier's risk by Road Transport only after getting dispatch clearance/purchase order from the purchaser.

b) **Loading & unloading of Ordered Materials.**

It will be the sole responsibility of the supplier for loading and unloading of materials both at the factory site and at the destination site/store. The Purchaser shall have no responsibility on this account.

11. **Supplier's Default Liability.**

(I) The Purchaser may, upon written notice of default to the supplier, terminate the contract in circumstances detailed hereunder.

a) If in the judgment of the Purchaser, the supplier fails to make delivery of equipment/material within the time specified in the contract or within the period for which if extension has been granted by the Purchaser in writing in response to written request of the supplier.

b) If in the judgment of the Purchaser, the supplier fails to comply with any of the provisions of this contract.

(II) In the event, Purchaser terminates the contract in whole or in part the Purchaser reserves the right to purchase upon such terms and in such a manner as he may deem appropriate in

relation to the equipment/material similar to that terminated and the supplier will be liable to the Purchaser for any additional costs for such similar equipment/material and/or for penalty for delay as defined in clause-23 of this section until such reasonable time as may be required for the final supply of equipment.

- (III) In the event the Purchaser does not terminate the contract supplier shall be liable to the Purchaser for penalty for delay as set out in Clause-23 of this section until the equipment is accepted. This shall be based only on written request of the supplier and written willingness of the Purchaser.

12. Force Majeure:

The supplier shall not be liable for any penalty for delay or for failure to perform the contract for reasons of force majeure such as acts of god, acts of the public enemy, acts of Govt., Fires, floods, epidemics, Quarantine restrictions, strikes, Freight Embargo and provided that the supplier shall within Ten (10) days from the beginning of delay on such account notify the purchaser in writing of the cause of delay. The purchaser shall verify the facts and grant such extension, if facts justify.

13. Extension of time:-

If the delivery of equipment/material is delayed due to reasons beyond the control of the supplier, the supplier shall without delay give notice to the purchaser in writing of his claim for an extension of time. The purchaser on receipt of such notice may or may not agree to extend the contract delivery date as may be reasonable but without prejudice to other terms and conditions of the contract.

14. Guarantee period: -

The cable trays and its accessories should be guaranteed for satisfactory utilization and against defects in design, materials and workmanship for a period of at least 24 (twenty four) months i.e. **Two years** from the last date of delivery. The above guarantee certificate shall be furnished in triplicate to the purchaser for his approval. Any defect noticed during this period should be rectified/replaced by the supplier free of cost to the purchaser provided such defects are due to faulty design, bad workmanship or bad materials used, within one month upon written notice from the purchaser failing which provision of clause 23 (ii) shall apply.

15. VAT REGISTRATION, VAT CELARANCE CERTIFICATION, PAN CARD &

AUTHORIZED DEALERSHIP CERTIFICATE : Attested legible Xerox copies of Income Tax PAN Card, VAT Registration & clearance Certificate & authorized dealership certificates (if applicable) valid on the date of opening of the tender should be submitted along with tenders without which tender will be rejected at the time of opening. If required,

the tenders shall have to produce original documents for verification any time after the opening of tender. Those who fail to produce the same and found not to be valid on the date of opening of the tender, their tenders will be rejected.

The bidders may also quote in CST Mode for which C- Form shall be supplied by the purchaser.

16. **TEST CERTIFICATE:** Necessary manufacturer certificate / test certificate in respect of the cable trays and its accessories shall be submitted before dispatch of materials for approval. Test certificate in respect of materials should conform to relevant IS as per the technical specification.
17. **SUBMISSION OF PROOF REGARDING MANUFACTURER'S CERTIFICATE/ AUTHORISED DEALERSHIP CERTIFICATE, PRICE LIST OF THE MANUFACTURER, PAST EXPERIENCE OF EXECUTION OF ORDER PERFORMANCE CERTIFICATE, TECHNICAL LITERATURE AND DRAWING OF LUMINAIRE AND DRIVER, TYPE TEST CERTIFICATE:**

Attested legible Xerox copies of necessary Manufacturer's certificate, valid authorized dealer certificate, Manufacturer's Price list and technical literature etc. should be furnished along with the tender. If required, the firms may be requested to produce such original certificates for verification. Past experience, if any, of execution of Purchase Orders need to be furnished by the bidders. The tender shall be accompanied with detail drawing and technical literature, leaflets, manuals if any.
18. **FREE REPLACEMENT:** Free replacement of materials lost / damaged during transit shall be made immediately on receipt of the intimation from the consignee /Paying Officer without waiting for settlement of the claim of bidders with Railway/Lorry/Insurance Company etc.
19. **STANDARDS:** The equipments shall strictly comply with relevant IS (Latest edition along with amendments if any) or equivalent standard as regards material, design, manufacture and testing etc.
20. **QUANTITY VARIATION:** The quantity to be ordered may undergo revision at the time of placement of orders.
21. **B.G. TOWARDS SECURITY DEPOSIT, 100% PAYMENT AND PERFORMANCE GUARANTEE:**
 - a) For manufacturers / dealers / suppliers situated Inside & outside the state of ODISHA.A Composite Bank Guarantee for 10% [ten percent] of the total FORD cost of the purchase order, shall be furnished from any nationalized/scheduled bank having a place of business at Bhubaneswar, to the office of General Manager EHT (O&M) Circle, Cuttack within 15 days from the date of issue of the purchase order,. The BG shall be executed on non judicial

stamp paper worth of Rs.29.00 [Rupees twenty nine] only or as per the prevalent rules, valid for a period of 2 months from the last date of guarantee period and submitted to the paying authority for scrutiny and acceptance, failing which the supply order will be liable for cancellation without any further written notices. The BG should be accompanied by a confirmation letter from the concerned bank and should have provision for encashment at Bhubaneswar, before the Bank Guarantee is accepted and all concerned intimated. The B.G should be revalidated as and when intimated to you to cover the entire guarantee period.

- b) No interest is payable on any kind of Bank Guarantee.
- c) In case of non-fulfillment of contractual obligation, as required in the detailed purchase order/Specification, the composite Bank guarantee shall be forfeited.
- d) The Bank Guarantee Format shall be provided by the Purchaser at the time of placing the Purchase Order

22. Terms of Payment.

- (i) 100% value of each consignment with 100% Excise duty, Entry Tax, if any, and sales tax in full as applicable along with freight & Insurance charges will be paid on receipt of materials in good condition at stores/desired site and verification thereof, subject to furnishing and approval of Composite Bank Guarantee at the rate of 10% (Ten percent) of the cost of supplied materials, as stipulated under clause-21 of this specification & on prior approval of guarantee certificate & Test certificate by the Purchaser. Income tax as applicable shall be deducted from the source.
- (ii) The supplier shall furnish Composite Bank Guarantee of appropriate amount to OPTCL covering 10% of F.O.R. Destination cost of the purchase order well in advance (within 15 days from the date of issue of the purchase order) before despatch of materials.

23. Penalty for Delay in Completion of Contract

- (A) If the Supplier fails to deliver the materials within the delivery schedule, specified in the contract including delivery time extension, if any, granted thereto, the Purchaser shall recover from the Supplier, penalty for a sum of half percent (0.5 percent) of the Ex-works price of the un-delivered equipment for each calendar week of delay or part thereof. For this purpose, the date of receipt of challan shall be reckoned as the date of delivery. The total amount of penalty shall not exceed five percent (5%) of the ex-works price of the unit or units so delayed. Equipment will be deemed to have been delivered only when all its components and accessories as per technical Specification are also delivered. If certain components & accessories are not delivered in time, the equipment will be considered delayed until such time as the missing parts are delivered.

(B) If the Supplier fails to replace the material within 30 days from the date of intimation of the defect, so noticed by the purchaser within the guarantee period then the penalty for sum of one half of the one percent (0.5%) of the total Purchase order amount for each calendar week of delay shall be recovered by the purchaser within the guarantee period. For this purpose, penalty date will start from the 30th. day from the date of issue of letter on defectiveness of material, so supplied, by the purchaser. The total amount of penalty in this case shall not exceed 10% (TEN PERCENT) of the purchase order amount. The purchase order amount shall mean ex-works price + freight & insurance and all taxes & duties. If the defects so intimated within the guarantee period will not be rectified by the Supplier within the stipulated period then whole of the B.G. will be forfeited by the purchaser, without any intimation to the Supplier.

24. Insurance

The Supplier shall undertake insurance of stores covered by this Specification unless otherwise stated. The responsibility of delivery of the stores at destination in good condition rests with the Supplier. Any claim with the Insurance Company or transport agency arising due to loss or damage in transit has to be settled by the supplier. The Supplier shall undertake free replacement of materials damaged or lost, which will be reported by the consignee within 30 days of receipt of the materials at destination without waiting for the settlement of their claims with the carriers and underwriters.

25. Payment Due from the Supplier

All costs and damages, for which the supplier is liable to the purchaser, will be deducted by the purchaser from any money, due to the supplier, under any of the contract (s), executed with OPTCL.

26. Certificate of Exemption from Excise Duty/Sales tax.

Offers with exemption from Excise duty including sales tax shall be accompanied with authenticated proof of such exemption. Authenticated proof for this clause shall mean attested Photostat copy of exemption certificate. Any claim towards Excise duty/ Sales Tax shall be paid on actual basis subject to production of authenticated documentary evidence.

27. Supplier's Responsibility.

Notwithstanding anything mentioned in the Specification or subsequent approval or acceptance by the Purchaser, the ultimate responsibility for design, manufacture, materials used and satisfactory performance shall rest with the Tenderers. The Supplier(s) shall be responsible for any discrepancy noticed in the documents, submitted by them along with the bid(s)

28. Jurisdiction of the High Court of ODISHA.

Suits, if any, arising out of this contract shall be filed by either Party in a court of Law to which the jurisdiction of High court of ODISHA extends.

29. Correspondences.

- i) Any notice to the supplier under the terms of the contract shall be served by Registered Post or by hand at the Supplier's Principal Place of Business.
- ii) Any notice to the Purchaser shall be served at the Purchaser's Principal Office in the same manner.

Official Address of the Parties to the Contract

The address of the parties to the contract shall be specified:-

- a) **Purchaser:** General Manager,
EHT (O&M) Circle, Cuttack, OPTCL
At :- Madhusudan Nagar, P.O:- Tulsipur, Cuttack, Odisha
Pin-753008
Telephone No. 0671 - 2300226
FAX No.0671 – 2300547
- b) **Supplier:** Address
Telephone No.
Fax No.

30. Outright Rejection of Tenders

Tenders shall be outrightly rejected if the followings are not complied with:

- a) The tenderer shall submit the bid in electronic mode only and shall submit the cost of tender document, EMD and Tender processing fee on or before the date and time of opening of the bid.
- b) The Tender shall not be submitted telegraphically or by FAX.
- c) The Tender shall be kept valid for a minimum period of 180 days from the date of opening of tender.
- d) The schedule of prices should be filled up fully to indicate the break-up of the prices including taxes and duties. Incomplete submission of this schedule will make the tender liable for rejection.
- e) The Tenderer should quote 'FIRM' price only and the price should be kept valid for a minimum period of 180 days from the date of opening of the tender.
- f) The prescribed EMD shall be submitted on or before the date and time of opening of the bid.
- g) **The tenders not accompanied with the required test certificates.**

- h) The tender shall not be conditional.
- i) There must not be any violation to the terms & conditions set forth and provided in the tender specification.
- j) Attested copies of I.T. Pan card and VAT registration certificate / VAT Clearance shall be submitted along with the tender.
- k) **The tenderer must submit sample of the items quoted along with the tender documents on or before tender opening time for sample scrutiny by the purchaser.**
- l) **Authorized dealership certificate issued by the manufacturers (In case of authorized dealer)**, valid on the date of opening of the tender shall be submitted along with the tender.
- m) There must not be any deviation to the delivery schedule as specified in tender specification.
- n) All the necessary excel sheets like techno-commercial bid sheet, pricebid sheet etc. attached with the tender should be duly filled up without any empty cells.

SECTION-III
[LIST OF ANNEXURES]

The following schedules and Performa are annexed to this specification and contained in Section-III as referred to in the relevant clauses.

1	Declaration form	ANNEXURE-I
2	Abstract of terms and conditions to accompany Section-II of Part-I	ANNEXURE-II
3	Bidders information	ANNEXURE-III
4	Schedule of Quantity and delivery schedule	ANNEXURE-IV

ANNEXURE - I
DECLARATION FORM

To

The General Manager (Elect)
EHT O&M Circle, OPTCL, Bhubaneswar

Sub:- Tender Specification No-_____

Sir,

1. Having examined the above specification together with terms & conditions referred to therein
* I/We the undersigned hereby offer to supply the materials/equipments covered therein complete in all respects as per the specification and General conditions, at the rates, entered in the attached contract schedule of prices in the Tender.

2. * I / We hereby undertake to have the materials/equipments delivered within the time specified in the Tender.

3. * I / We hereby guarantee the technical particulars given in the Tender supported with necessary reports from concerned authorities.

4. * I/We certify to have submitted the bid electronically by remitting *online payment /D.D./ remitting the cost of tender, herewith and this has been acknowledged by your letter / receipt No. _____ Dated_____

5. In the event of Tender, being decided in *my/our favour, * I/We agree to furnish the Composite B.G. in the manner, acceptable to ODISHA POWER TRANSMISSION CORPORATION LTD., and for the sum as applicable to *me/us as per clause-21 of section-II of this specification within 15 days of issue of letter of intent/purchase order failing which *I/We clearly understand that the said letter of Intent/Purchase order will be liable to be withdrawn by the purchaser, and the EMD deposited by us shall be forfeited by OPTCL.

Signed this day of 20____

Yours faithfully

Signature of the Tenderer
with seal of the company

[This form should be dully filled in by the tenderer and uploaded at the time of submission of tender.]

* (Strikeout whichever is not applicable).

ANNEXURE-II

ABSTRACT OF GENERAL TERMS AND CONDITIONS OF CONTRACT [COMMERCIAL] TO ACCOMPANY PART-I

1(a)	Cost of Tender Document: OPTCL Money Receipt No. & Date / D.D No & Date.	
1(b)	Earnest money furnished. Bank Guarantee No. & Date / D.D No. & Date.	
1(c)	Tender Processing Fee: e-payment confirmation	
2	Manufacturer's supply experience including user's certificate furnished or not.	<i>Yes/No</i>
3	Delivery :- Whether agreeable to OPTCL's desired delivery period as indicated at in the specification	<i>Yes/No</i>
4	Guarantee:- Whether agreeable to OPTCL's terms.	Yes/No
5	Whether agreeable to furnish Composite B.G. in case his tender be successful	Yes/No
6.	Terms of payment:- Whether agreeable to OPTCL's terms or not	Yes/No.
7.	Nature of price:- FIRM	Yes/No
8.	Penalty:- Whether agreeable to OPTCL's terms or not	Yes/No
9.	Validity :- Whether agreeable to OPTCL's terms or not	Yes/No
10.	Whether recent type test certificates from any Government approved laboratory are furnished or not.	Yes/No
11.	Whether materials are ISI/ISO marked.	Yes/No
12.	Furnished Manufacturer's name and its trademark.	Yes/No
13.	Whether registered under ODISHA Sales Tax Act. 1947	Yes/No
14.	Whether declaration form duly filled in furnished or not.	Yes/No.

Place: -

Date: -

Signature of the Tenderer
with seal of the company

ANNEXURE-III
BIDDER'S INFORMATION

SL NO	The bidder shall furnish general information in the following format	
	NAME OF THE BIDDER	
1	Address:-	
2	City	
3	Pin Code	
4	Contact person's Name :-	
5	Telephone No. office & Residence:-	
6	FAX No:-	
7	EMAIL:-	
9	SERVICE TAX REGISTRATION NO.	
10	PAN NO.	

ANNEXURE-IV

SCHEDULE OF QUANTITY ALONG WITH DELIVERY SCHEDULE

<i>Sl. No</i>	<i>Description of Material</i>	<i>Unit</i>	<i>Qty</i>
	Supply of Perforated type Aluminium Cable Trays of different sizes with black powder coating along with required side coupler plates and hardwares as per specification		
1.	Perforated Cable Tray (Dimensions in MM)		
a)	W x L x H x Thk = 450 x 2500 (±10) X 50 x 3	Nos	212
b)	W x L x H x Thk = 200 x 2500 X 50 x 3	Nos	159
2.	Perforated type Aluminium 90° Horizontal Tee Section with black powder coating along with required coupler and hardwares (Dimensions in MM)		
a)	W x H x Thk = 450 x 50 x 3	Nos	20
3.	Perforated type Aluminium 90° Horizontal Bend with black powder coating along with required coupler and hardwares (Dimensions in MM)		
a)	W x H x Thk = 450 x 50 x 3	Nos	10
4.	Perforated type Aluminium Central Reducer with black powder coating along with required coupler and hardwares (Dimensions in MM)		
a)	Width reduction From 450mm to 200mm, H = 50mm,	Nos	20

DELIVERY SITE: 132/33KV Grid Sub-station, Kendrapada

N.B: The detailed address for the above delivery locations shall be provided at the time of the placement of Purchase Order.

PART-I(SECTION-IV)

TECHNICAL SPECIFICATION FOR PERFORATED CABLE TRAY WITH REQUIRED ACCESSORIES MADE UP OF POWDER COATED ALUMINIUM / ALUMINIUM ALLOY SHEET

1. **Material** : Aluminium / Aluminium Alloys 19000 tempering H2 material
2. **Perforated Cable Tray**
Sizes: 450mm (Width) x 50mm (height of both side) x 3mm (Thickness)
200mm (Width) x 50mm (height of both side) x 3mm (Thickness)
Standard length of Cable Tray: 2500 (±10) MM
3. **Cable Tray Coupler (Plate Type) with four holes and four slots for fastening.**
Size: 50mm (Width) x 220mm (Length) x 3mm (Thickness)
4. **Perforated type 90° Horizontal Tee Section**
Size: 450mm (Width) x 50mm (Height) x 3mm (Thickness)
5. **Perforated type 90° Horizontal Bend**
Size: 450mm (Width) x 50mm (Height) x 3mm (Thickness)
6. **Perforated type Central Reducer**
Size: 450mm (Width) x 50mm (Height) x 3mm (Thickness)
7. **Surface Finish:** Well fabricated with good quality dry type black color powder coating. The perforations and the ends of the cable trays and including accessories should not have any burrs and ragged edges and be of smooth surface finish.
8. **IS Standards:**
 - a) The cable tray including bends and tees should conform to **IS 737: 1986** for wrought aluminium and aluminium alloy sheet and strip for general engineering purposes and
 - b) The Nuts and bolts along with the washers should conform to **IS 1363:1967** (Specification for Hex bolts), **IS 1367: 1961** (Specification of fasteners) and **IS 2629: 1985** (Recommended Practice of Hot-Dip Galvanizing of Iron and Steel)
9. **Tests** : The material shall conform to the following tests
 - a) Chemical composition test as per IS 2062 (2006) Grade A
 - b) Mechanical / Bending test as per IS 2062
 - c) Galvanizing test as per I.S. 6745, 2629, 2633, 4759.
 - i. Uniformity of Zinc
 - ii. Adhesion test
 - iii. Mass of zinc
 - iv. Thickness of Zinc

N.B:

- ALL THE CERTIFICATES AND TEST REPORTS SHOULD BE VALID FOR THE DURATION OF TENDER OPENING TO TENDER FINALIZATION

GENERAL MANAGER

EHT (O&M), CIRCLE, CUTTACK

**RELATED DIAGRAMS FOR PERFORATED CABLE TRAYS AND OTHER
ACCESSORIES (ALL DIMENSIONS ARE IN MM)**

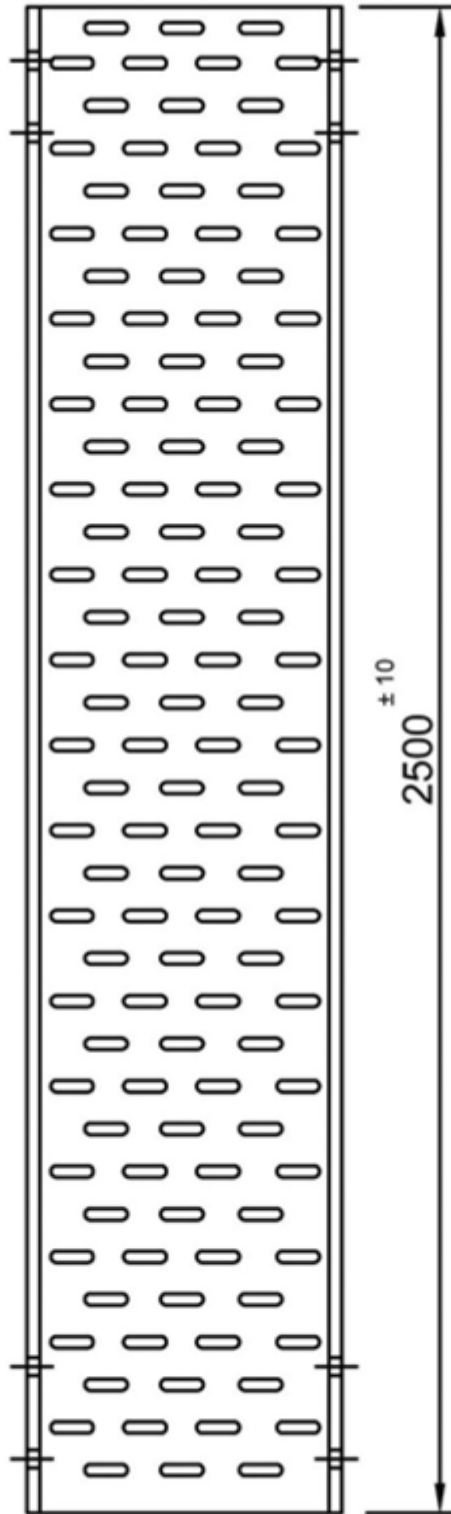
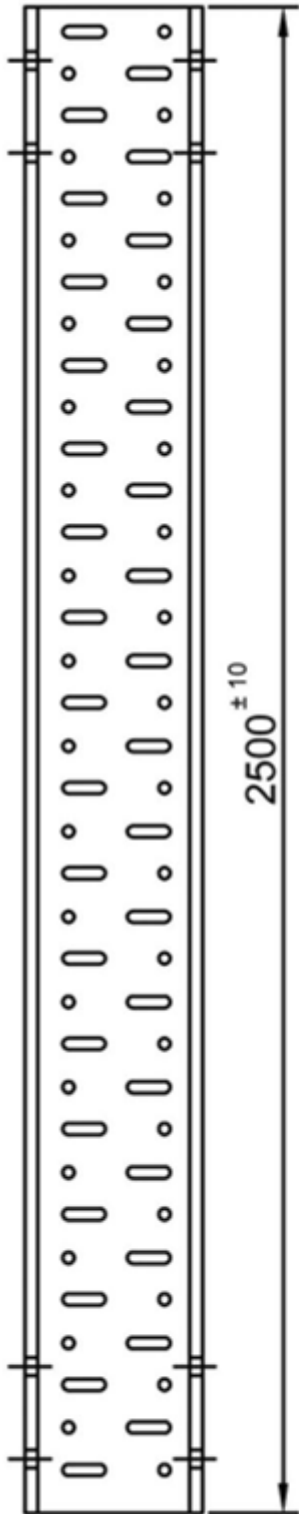

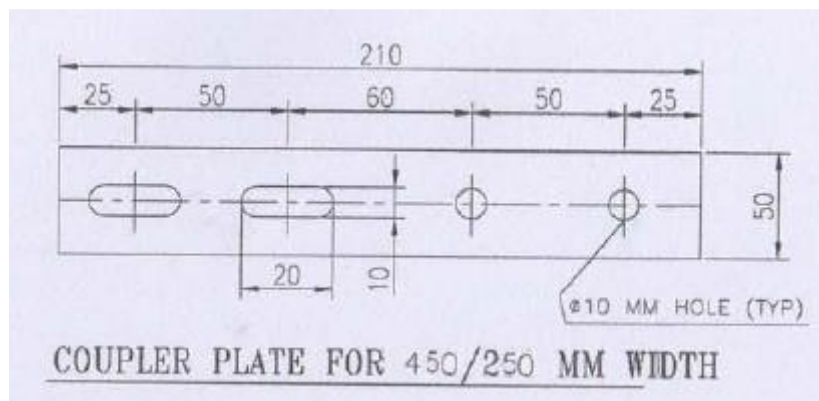
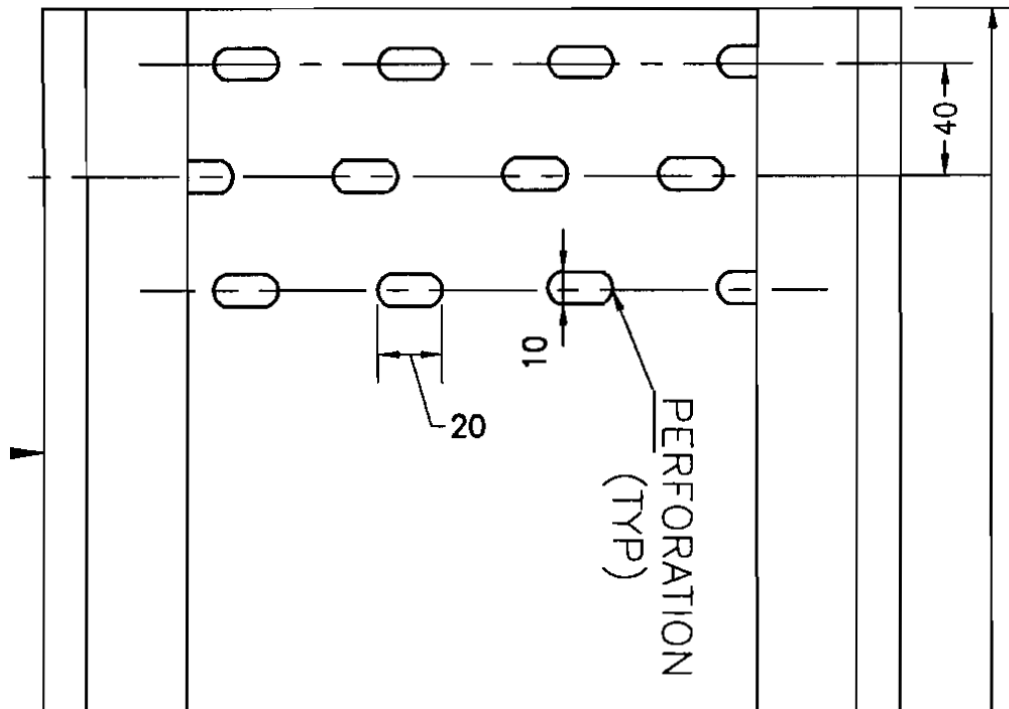
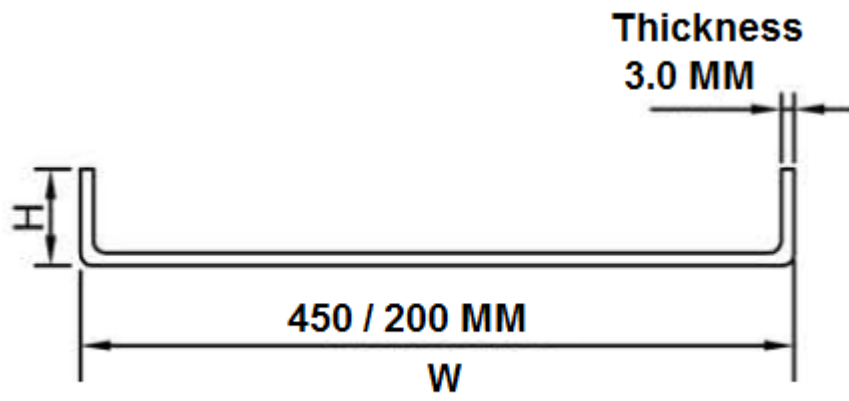



ELECTRO GALVANIZED BOLT, WASHER & NUT FOR SIDE COUPLER PLATE

