

ଓଡ଼ିଶା ଶକ୍ତି ସଂଚାରଣ ନିଗମ ଲିମିଟେଡ.
ODISHA POWER TRANSMISSION CORPORATION LIMITED

(A Govt. of Odisha undertaking)

CIN – U40102OR2004SGC007553

REGD. OFFICE: JANPATH, BHUBANESWAR-751022,
OFFICE OF THE DEPUTY GENERAL MANAGER (Elect)
EHT (O&M) DIVISION, MERAMUNDALI
At- Kantabania, PO- Kusupanga, Dist- Dhenkanal

E-mail-ehm.div.mrm@optcl.co.in

TENDER SPECIFICATION FOR TENDER CALL NOTICE NO. 02 /2019-20

**DESIGN, SUPPLY AND INSTALLATION OF DIFFERENT TYPES OF SIGN BOARD FOR
400/220/132 KV GRID S/S, MERAMUNDALI UNDER EHT (O&M) DIVISION,
MERAMUNDALI.**

COST OF TENDER PAPER

Rs. 2,000/- + 12% GST=Rs.2, 240 /-

(Rupees Two Thousand Two Hundred Forty only)

ISSUED TO

M/S

.....

.....

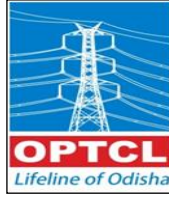

ଓଡ଼ିଶା ଶକ୍ତି ସଂଚାରଣ ନିଗମ ଲିଃ.
ODISHA POWER TRANSMISSION CORPORATION LTD
(A Govt. of Odisha undertaking)
CIN – U40102OR2004SGC007553
REGD. OFFICE: JANPATH, BHUBANESWAE-751022
OFFICE OF THE DEPUTY GENERAL MANAGER (Elect)
EHT (O&M) DIVISION, MERAMUNDALI,
At- Kantabania, PO- Kusupanga, Dist- Dhenkanal, PIN- 759121.
E-mail-ehm.div.mrm@optcl.co.in

TENDER SPECIFICATION FOR TENDER CALL NOTICE NO. 21/2018-19.

FOR PROCUREMENT OF DIFFERENT ELECTRICAL ITEMS TO BE USED AT 400/220/132 KV GRID S/S, MERAMUNDALI UNDER EHT (O&M) DIVISION, MERAMUNDALI.

- | | | |
|-----|---|--|
| 1. | SECTION-I | Instruction to bidders. |
| 2. | SECTION-II | General Condition of contract. |
| 3. | SECTION-III | Technical Specification |
| (a) | Annexure-I | (Scope of Supply) |
| (b) | Annexure-II | (Price schedule) |
| 4. | SECTION- IV | Declaration Form |
| 5. | Price of tender document | Rs. 2000/-+12 % GST =Rs 2,240/-
(Rupees two thousand two hundred forty) only. |
| 6. | COMMENCEMENT OF SALE OF TENDER PAPER. | 01.11.2019 (11.00 AM to 5.00 P.M.) |
| 7. | LAST DATE OF SALE OF TENDER PAPER. | 22.11.2019 (11.00 AM to 5.00 P.M.) |
| 8. | LAST DATE & TIME OF RECEIPT OF TENDER PAPER. | 22.11.2019 (Up to 1.00 P.M.) |
| 9. | DATE & TIME OF OPENING OF TENDER. | 22.11.2019 (At 3.30 P.M.) |

TENDER CALL NOTICE NO. 02/ 2019-20

The Dy. General Manager (Elect.), E.H.T. (O&M) Division, Meramundali invites sealed Tenders from intending Manufacturers/Authorized Dealers/Reputed Supplier for Design, Supply and Installation of different types of Sign Board for 400/220/132 kV Grid S/S, Meramundali under EHT (O&M) Division, Meramundali as follows.

Sl. no.	Description	Place of Delivery	Cost of Tender Paper
1	Design, Supply and Installation of different types of Sign Board for 400/220/132 kV Grid S/S, Meramundali.	400/220/132 KV Grid S/S, Meramundali	Rs.2000/- + GST 12%

The tender specification can be obtained from the office of The DGM EHT (O&M) Division, MERAMUNDALI on payment of Rs. **2000/- (Two Thousand only) + GST @ 12%** (Non-Refundable) in shape of Cash/ Bank Draft in favor of DGM, EHT (O&M) Division, MERAMUNDALI payable at "STATE BANK OF INDIA", Bhushan Steel Plant, Narendrapur Branch on any working day from **Dt. 01.11.2019 to Dt. 22.11.2019**. In case the D.D made at any other nationalized bank payable at any clearing branch at Talcher/Angul will be allowed, but the bidders have to deposit the collection fee (Bank transaction fee) along with the paper cost. The collection fee & Paper cost is Non-refundable. Additional amount of Rs.100/-(One Hundred only) may be paid extra for postal delivery of the tender specification. The undersigned shall not be held responsible for any postal delay.

The Tender shall be received by **01.00 PM** on dated **22.11.2019** & will be opened at **03.30 PM** on same day in the Office of the undersigned in the presence of the Bidders (or) their Authorized Representatives present if any. If any of the above date happens to be a holiday, the next working day will be the corresponding effective date. One Tender paper shall be issued to each Bidder. E.M.D of Rs. 5000.00 (Rupees Five Thousand only) should be deposited in shape of Cash /Demand Draft in favour of **E.H.T. (O&M) Division, Meramundali & payable at "STATE BANK OF INDIA", Bhushan Steel Plant, Narendrapur Branch.**

The Bidder should super scribe only the "Tender Call Notice No. & Date of Opening of the tender on the body of the Sealed Envelope". Bidder should not write their name or any other information on the body of the sealed envelope. Superscribing any other information on the body of the envelope, Conditional tender, Incomplete tender, Telegraphic / Fax / E-mail (etc.) Tenders & Tenders not accompanied with requisite amount of E.M.D. will be rejected. The authority reserves all rights to reject any, all or part of the Tender, alter/modify the requirement/ delete any part of the tender without assigning any reason thereof. N.B:- Tender Paper must be purchased from this office only. No other mode like downloaded paper from website will be accepted.

Dy. General Manager
EHT (O&M) Division, Meramundali

SECTION-I
INSTRUCTION TO BIDDERS

1. Sealed Tenders from intending Manufacturers/Authorized Dealers/Reputed Supplier with valid PAN and GST registration for Design, Supply and Installation of different types of Sign Board for 400/220/132 kV Grid S/S, Meramundali under EHT (O&M) Division, Meramundali.

2. **SCOPE OF SUPPLY:** The Scope of Supply is enclosed in Annexure-I of Section-III.

3. SUBMISSION & OPENING OF TENDER:-

The bidder has to submit all the documents as mentioned in Clause No.08 (A) of SECTION-I. Also the documents must be valid on the date of opening of tender and should be submitted along with tenders, failing which the tender will be rejected. The bidder or their authorized representatives should produce the original documents mentioned in Clause No.08 (A) of SECTION-I for verification at the time of opening of the tender. Those who fail to produce the same and found not to be valid on the date of opening of tender not matching with the Xerox copy submitted by the bidder; their tenders will be out rightly rejected. In case if only one bidder participates in the tender process or nature of urgency of work (decided by this office), then undersigned may consider the case (*but not mandatory) & he will be given a chance to produce original documents in this office within one week from the date of opening of the tender.

4. RIGHT & AUTHORITY FOR REJECTION: -

Tenders received after due date and time will be summarily rejected. The Dy.General Manager (Electrical), E.H.T. (O&M) Division, Meramundali reserves the right to reject any or all of the tenders without assigning any reason thereof.

5. VALIDITY OF OFFER: -

The offer should be firm and valid for a period of at least 180 days from the date of opening of tenders, or else the tender will be out rightly rejected.

6. EARNEST MONEY DEPOSIT: -

The tender should be accompanied with **Rs. 5000.00 (Rupees Five Thousand only)** towards Earnest Money Deposit (EMD) either in shape of Cash/ Bank Draft in favour of EHT (O&M) DIVISION, MERAMUNDALI payable at "STATE BANK OF INDIA", Bhushan Steel Plant, Narendrapur Branch otherwise tender will be out rightly rejected. In case the D.D made on any other nationalized bank payable at any clearing branch at Talcher/Angul will be allowed, but the bidders have to deposit the collection fee (Bank transaction fee) along with the EMD. The collection fee is Non-refundable & it can't be taken into account of EMD deposit. The EMD of the unsuccessful Bidders will be returned after finalization of tender. The EMD of the successful Bidders will be returned only after satisfactory execution of order. In case successful Bidder fails to execute the order satisfying all terms & conditions & scope of work within stipulated date mentioned in the date of order, the Earnest Money Deposit will be forfeited. No interest will be paid on the EMD.

7. SECURITY DEPOSIT: -

The Tenderers whose offer qualifies for acceptance will be awarded the contract and the contractor shall have to deposit security amount equal to 10% (ten percent) of contract value in shape of Bank Draft drawn in favour of *paying officer* of OPTCL. The Security deposit shall be released after one year of the verification of materials subject to fulfillment of the guarantee stated under clause – 11 of Section-III on receipt of application for this purpose. No interest shall be paid to the supplier towards the security deposit so deposited by the supplier. The security deposit shall be deposited with the *paying officer of OPTCL Prior to execution of the contract*. In case of non-deposit of Security Amount, then same will be deducted from the final bill.

8. (A) DOCUMENTS:-

- i) Valid GST Registration Certificate
 - ii) Valid PAN/ TIN.
 - iii) Manufacturer's Certificate// Authorized Dealership Certificate
- (B)** i) Past Experience of Supply to any PSUs/OPTCL
- ii) Performance Certificate

9. CORRECTIONS, OVER-WRITINGS AND ILLEGIBILITY:

Tender with over writing, erased, illegible rates or rates not shown in figures and words in English will be liable for rejection. In case of discrepancy between words and figures noted against each item of the tender and between unit rates and total amount, the decision of the Competent Authority accepting the tender will be final and binding on the bidders. Total of item and grand total of whole tender must be clearly written.

Correction in the tender, if un-avoidable, should be made by re-writing with dated initial of the bidder after scoring out wrong entries, clerical and arithmetical mistakes may result in the rejection of the tender.

10. The bidder shall sign on all pages of the tender document as a token of acceptance of all terms and conditions thereof and submit his quotations therein.

11. The bidder shall quote the rates in the Price Bid of the tender documents. The rates quoted should be including of all taxes and duties but exclusive of GST.

12. Request from the bidder in respect of additions, alterations, modifications, corrections of either terms or conditions or rates after opening of the tender will not be considered.

13. All correspondence relating to the tender shall be made with Dy.General Manager (El.), E.H.T. (O&M) Division, OPTCL, Meramundali.

14. ADDITION OR DELETION OF SCOPE: - The Purchaser may alter the quantities at the time of placing orders. Initially the purchaser may place orders for lesser quantity with full freedom to place extension orders for further quantity under similar terms and conditions of the original orders. Orders may also be split among more than one tenderer for any particular item, if considered necessary in the interest of the Purchaser to get the goods/equipment earlier.

15. ARBITRATION: - In the event of any dispute arising out his contract. The same shall be referred for arbitration to the Director (HRD) OPTCL, Bhubaneswar or any arbitrator appointed by the Chairman- Cum- Managing Director, OPTCL after due notice of claim and such appointment and the award of the arbitrator shall be final and binding arbitration and conciliation Act. 1996 shall apply. The venue of arbitration will be Bhubaneswar.

SECTION-II
GENERAL TERMS & CONDITIONS

1. PRICE: -

(a) The price quoted should be firm, F.O.R. destination inclusive of Design, Fabrication, Supply, Installation charges inclusive discount if any.

(b) Taxes, if any shall be mentioned extra. The tenderer may quote rate in respect of Different make Materials as per scheduled.

2. VALIDITY: -

The offer should be valid for at least a period of **180 (one hundred eighty)** days from the date of opening of the tender.

3. TERMS OF PAYMENT: -

100 % Payment with taxes etc. against Security Deposit else 90% shall be made within 30 days after receipt and installation of materials in full and in good condition & verification thereof by the consignee subject to availability of funds from Head office.

4. DELIVERY:-

The materials in full quantity shall be delivered & installed within 45 days of receipt of purchase order, failing which purchase order shall be liable for cancellation with forfeiture of Earnest money/ Security Deposit. However early delivery shall be preferred.

5. PENALTY FOR DELAY IN DELIVERY:

If the supplier shall fail to deliver the materials within the delivery period as stipulated under clause No.4 (Section-III) of this Tender document or any extension granted there to, the purchaser shall recover from the supplier penalty for a sum of half percent (i.e. 0.5 percent) of the contract price for each calendar week or part thereof of delay. However the total amount of penalty shall not exceed 5% (five percent) of the contract/undelivered items price. Materials will be deemed to have been delivered only when all the component parts are also delivered. If certain components are not delivered in time, the supply will be treated as delayed until the time, the missing/ undelivered parts are delivered.

6. EXTENSION OF TIME: If the delivery of materials is delayed due to reason beyond the control of supplier, the supplier shall without delay give justification. The purchaser on receipt of such notice may agree to extend the contract delivery date if reasonable but without prejudice to other terms and conditions of this contract

7. EARNEST MONEY: - The Tenderers are requested to deposit EMD of **Rs. 5000.00 (Rupees Five Thousand only)** in shape of cash/ demand draft in favour of E.H.T. (O&M) Division, OPTCL, Meramundali and payable at "STATE BANK OF INDIA", Bhushan Steel Plant, Narendrapur Branch. The EMD will be refunded to the un-successful bidders, after finalization of tender. The EMD of Successful bidder will be refunded after award of finalization of contract on submission of security deposit. The EMD submitted by the contractors along with their bids shall not carry any interest from OPTCL. The Tender without EMD will be summarily rejected.

8. INSURANCE: Insurance of materials is to be done by the supplier at their own cost. The responsibility of delivery of the materials at destination in good condition rests with the supplier. Any claim with the insurance company, Railway authority/ Road transport authorities arising due to loss or damage in transits has to be settled by the supplier. *The supplier shall undertake free replacement of materials damage or lost which will be reported by the consignee within 30 Days of the receipt of the materials at destination without waiting for the settlement of the claims with the carriers and underwriters.*

9. DESPATCH INSTRUCTIONS: The materials should be securely packed and dispatched by Rail/ road transport at locations as mentioned below to the consignee. The cost of transportation will be borne by the supplier.

10. FREE REPLACEMENT: Free replacement of materials lost/ damaged due to transit shall be made immediately on receipt of the intimation from the consignee / paying Officer without waiting for settlement of the claim of bidders with Railway/ Lorry/ Insurance Company.

11. GUARANTEE: - The materials covered under this contract should be guaranteed for trouble free and satisfactory performance against any defect in design, materials and workmanship for a Period of 12 months from the date of delivery. Any defect noticed during this period should be rectified / replaced by the firm free of cost provided such defects are due to faulty design, bad workmanship or bad materials used. *The replaced materials should also have similar guarantee. The guarantee certificate in triplicate should be submitted to the office of the undersigned for necessary approval.*

12. Security Deposit:

- i) The successful bidder has to submit security deposit in shape of DD or cash i.e. 10% value of the work order/purchase order in favour of *E.H.T (O&M) Division, Meramundali.*
- ii) No interest is payable on security deposit.
- iii) In case of non-fulfillment of contractual obligation as required in the detailed purchase order / specification, the security deposit shall be forfeited.
- iv) The security deposit shall be refunded only after successful completion of guarantee period and after adjustment of any dues.
- v) The security deposit should be submitted separately to each paying authority.
- vi) **In case of non-deposit of the security amount, the same will be deducted from the bill.**

13. STANDARD: The materials offered self-confirm to relevant IS & ISI standard.

14. ADDITION & ALTERATION: -The authority reserves the right to add or to reduce the quantum of materials without assigning any reasons thereof.

15. RIGHT TO REJECT / ACCEPT ANY TENDER: -The Authority reserves the right, either to reject or accept any or all the tenders without assigning any reasons thereof.

16. JURISDICTION OF THE COURT: -For the purpose of jurisdiction of court in the event of dispute if any shall be deemed to have entered into any court of law to which the jurisdiction of Orissa High Court extends and it is hereby expressly agreed that neither party shall be competent to bring a suit in regard to the matter covered by this purchase at any place outside State of Odisha.

17. SUBMISSION OF GST REGISTRATION CERTIFICATE:-Clear attested Xerox copies of PAN No. & GST Registration certificate should be submitted along with the tender, failing which, the tender will be rejected.

18. LANGUAGE AND MEASURES: - All documents pertaining to the contract including Specifications, Schedule, Notices, Correspondence, Operating and Maintenance instructions, Drawings or any other writing shall be written in English language. The metric system of measurement shall be used exclusively in this contract.

19. DEVIATION FROM SPECIFICATION: -It is in the interest of the Tenderers to study the Specification, works etc. specified in the tender should thoroughly before tendering so that, if any deviations are made by the Tenderers, the same are prominently brought out on a separate sheet under heading "Deviations". A list of deviation shall be enclosed with the Tender. Unless deviation in scope, technical and commercial stipulations are specifically mentioned in the list of deviations, it shall be presumed that the Tenderer has accepted all the conditions stipulated in the Tender Specification, notwithstanding any exemptions mentioned therein.

20. RIGHT TO REJECT / ACCEPT ANY TENDER: -The owner reserves the right either to reject or to accept any or all tenders if the situation so warrants in the interest of the organization. Orders may also be split up between different Tenderers on individual merits of the Tenderer. **Orders may also be split among more than one tenderer for any particular item/s on basis of L1 price of independent items, if considered necessary in the interest of the Purchaser.** It may be clearly understood by the Tenderer, that the owner need not assign any reason for the above action (s).

21. CONTRACTOR TO INFORM HIMSELF FULLY: - The Contractor shall examine the instructions to Tenderers, General Conditions of contract, Specification and the Schedules of Quantity and delivery to satisfy himself as to all terms and conditions and circumstances affecting the contract price. He shall quote price(s) according to his own views on these matters and understand that additional allowances except as otherwise provided therein will be levied. The owner shall not be responsible for any misunderstanding or incorrect information obtained by the Contractor other than the information given to the Contractor in writing by the owner.

22. FORCE MAJEURE: - The Contractor shall not be liable for any penalty for delay or for failure to perform the contract for reasons of force Majeure such as acts of God, acts of the public enemy, acts of Govt., Fires, Floods, Epidemics, Quarantine restrictions, strikes, Freight Embargo, provided that the Contractor shall within ten (10) days from the beginning of such delay notify the owner in writing of the clause of delay, upon which, the owner shall verify the facts and grant such extension as facts justify.

23. CORRESPONDENCES:

- i) Any notice to the Contractor under the terms of the contract shall be served by Registered Post or by hand at the Contractor's Principal Place of Business.
- ii) Any notice to the owner shall be served at the owner's Principal office in the same manner.
- iii) The address with Telephone No. should be given for immediate contract in case of any problems and negligence or emergency duties.

24. OUTRIGHT REJECTION OF TENDERS: - Tenders shall be outrightly rejected if they are not complying with the following requirements:

- i) The Tenderer shall submit the bid before submission date & time and shall submit the cost of tender documents.
- ii) Tenders shall not be submitted telegraphically or by FAX.
- iii) Tenders shall be accompanied by the prescribed Earnest Money Deposit on or before the date & time of opening of the bid unless otherwise qualified for exemption from furnishing of EMD.
- iv) The bidder having any pending legal suit against the organization.
- v) For any warning for unsatisfactory works taken up or termination of agreement for similar works by OPTCL.
- vi) The tender should quote "firm" price only and the price should be kept valid for a minimum period of 180 days from the date of opening of the tender.

25. DOCUMENTS TO BE TREATED AS CONFIDENTIAL:

The Contractor shall treat the details of the Specification and other Tender documents as private and confidential and they shall not be reproduced without authorization from the Purchaser.

26. Consignee : Manager, 400/220/132 KV Grid s/s, Meramundali.

27. Paying Officer : Dy.GM (Elect.), EHT (O&M) Division, Meramundali.

SECTION-III
ANNEXURE-I (SCOPE OF SUPPLY)

TECHNICAL SPECIFICATIONS AND DESIGN DETAILS OF VARIOUS SIGNAGES

1. SCOPE

- a. This document covers the architectural design concepts, technical specification & suggested details for the manufacturing of the signage. Detailed designing, construction, fabrication, assembling including finishing should be carried out by the vendor and shall conform in all respects to high standards of design, engineering & workmanship.
- b. The drawing given with the tender for different signage elements is indicative. The detailed fabrication drawing, shop drawing, mock ups, fixing details, design to fit size should be developed by the vendor and submitted to OPTCL for approval. The vendor shall develop the prototype for each category as per the approved drawing, graphic detail and submit to OPTCL for approval. Prototype should be offered for inspection and approval complete in all respects including fabrication of frame/structure, graphic application, including testing and functioning of the sign complete in all respects.
- c. Detailed assessments and provision should be made for ease of internal & external maintenance.

2. BASIS OF DESIGN

- a. All signage covered under this specification shall be good for installation and operation in OPTCL at 400 kV Grid S/S, Meramundali, Kantabania, Dist.: Dhenkanal, Odisha in India.
- b. All signage, except where specified as indoor, shall be good for outdoor installation without any shade/cover/protection.
- c. All outdoor signage should be designed to withstand all climatic conditions.
- d. The design of signage shall facilitate easy maintenance.

3. CODES AND STANDARDS

The signage supplied by the vendor shall conform in all respect to the standard listed below. Latest editions of these specifications shall be referred.

Stainless Steel: - IS: 5522, IS: 15997 and IS: 6911: Stainless Steel (SS) alloy should be SS 304 grade. This offers excellent corrosion resistance and effectively combats tarnishing under most circumstances.

Aluminium composite panels (ACP): IS 733

4. COLOURS

Colour of the signage shall comply with approved shades. Vendor shall submit colour samples of vinyl film & paint to obtain clearance before proceeding with the art/painting work for all relevant signage.

5. TESTING OF MATERIALS

All the materials shall be procured from approved manufacturer as per the specification and shall be accompanied by Manufacturer Test certificate.

6. INSPECTION OF WORK

Vendor to facilitate to carry out the inspection of materials, works, fabrication at their works and at the site during the installation by OPTCL representative as per the scope of work.

7. TECHNICAL SPECIFICATION OF MATERIAL

Specification for vinyl

Property Value

Tensile Strength 0.8-0.9 kg/cm at 23°C

Applied Shrinkage Max 0.5mm

Service Temperature -40°C to +75°C

Adhesion Strength Acrylic, Uncoated, clear Polycarbonate 0.5 kg/cm

Film Characteristics

Film Description 0.050mm translucent vinyl

Thickness film & adhesive 3 to 4 mil (0.08 to 0.010mm)

Adhesive type & colour

Permanent pressure sensitive clear adhesive

Liner Synthetic liner

Application Surfaces Flat without rivets

Min Application Temperature 16°C

The vinyl should be RoHS complaint, confirming to EU RoHS standards

Warranty:

- Contractor should provide a Comprehensive Warranty from the single source manufacturer of the translucent vinyl and the flexible substrate for a period of at least 6 years.
 - On completion of work, the Contractor must submit a warranty document from the Principal Manufacturer having direct presence in India (not Liaison office / dealer / Representative Office / Distributor / Agents / Reseller / Importer) of the translucent vinyl and the flexible substrate.
 - The Authorized personnel of the Indian Subsidiary / branch of the Principal Manufacturer should validate the Comprehensive Warranty with the Name clearly indicated and signature provided for the same.
 - The Contractor should be an Authorized Contractor of the Indian Subsidiary / branch of the Principal Manufacturer of the translucent vinyl and the flexible substrate.
 - Warranty should be issued by a notified solution provider by virtue of being a branch / subsidiary and enforceable in Indian Law court.
 - The Signs should be warranted by the Indian subsidiary / branch of the Principal Manufacturer for all sorts of Indian weather and dust conditions without any sub clauses for high Traffic areas / high Pollution areas / high temperature areas.
 - This means that there should be tested field warranties and not just product warranties.
- Warranty should be against: Vinyl peel-off, fading, shrinkage, cracking and crazing
- The Authorized Contractor's final bills would be cleared only on submission of the duly endorsed Warranty Documents that fulfil all the above conditions.

8. LIST OF APPROVED MAKE OF MATERIALS

<u>Sr. No</u>	<u>Materials</u>	<u>Approved makes</u>
1.	ACP (3 mm / 0.3 mm thick)	Alpolic, Alco bond, Renybond
2.	Vinyl	3M (Scotchall 3630 series, 3650 series, 7725 series)
3.	Steel	SAIL, Tata, Jindal
4.	Retro reflective sheet	3M (Reflective H I grade)
5.	Laminate film	3M (Series – 8519)

ANNEXURE-II

PRICE SCHEDULE

SL. No.	Description	Unit	Quantity	Rate	Amount
	<u>TYPE-A</u> Bay Identification/ Direction Board. Retro Reflecting Sticker on ACP (3.0 MM/0.3 MM) Board with S.S (Grade-304) Frame and Single Stand with fixing in ground by concrete (1:2:4) as per instruction of Engineer-in-charge.				
A(i)	One Side Sticker Size- 1'0" X 1'0" = 1.0 Sq.ft. 73 Nos. = 73 X 1.0 = 73.0 Sq.ft.	Sq.ft.	73		
A(ii)	Both Side Sticker Size- 1'0" X 1'0" = 1.0 Sq.ft. 04 Nos. = 4 X 1.0 = 4.0 Sq.ft.	Sq.ft.	4		
A(iii)	One Side Sticker Size- 3'0" X 1'6" = 4.5 Sq.ft. 01 No. = 1 X 4.5 = 4.5 Sq.ft.	Sq.ft.	4.5		
	<u>TYPE-B</u> Line/Bay/Bus Identification Board of ACP (3.0 MM/0.3 MM) with Retro Reflecting Sticker with S.S (Grade-304) Frame and provision for structure/Gate mounting.				
B(i)	One Side Sticker Size- 1'0" X 1'0" = 1.0 Sq.ft. 304 Nos. = 3.04 X 1.0 = 304.0 Sq.ft.	Sq.ft.	304		
B(ii)	One Side Sticker Size- 1'6" X 2'0" = 3.0 Sq.ft. 10 Nos. = 3.0 X 10.0 = 30.0 Sq.ft.	Sq.ft.	30		
	<u>TYPE-C</u> Identification Board of ACP (3.0 MM/0.3 MM) with Retro Reflecting Sticker with S.S (Grade-304) Frame with Double Stand with fixing by concrete (1:2:4) as per instruction of Engineer-in-charge.				
C(i)	One Side Sticker Size- 3'0" X 1'6" = 4.5 Sq.ft. 3 Nos. = 3 X 4.5 = 13.5 Sq.ft.	Sq.ft.	13.5		
C(ii)	One Side Sticker Size- 1'6" X 1'6" = 2.25 Sq.ft. 12 Nos. = 12 X 2.25 = 27.0 Sq.ft.	Sq.ft.	27		
C(iii)	One Side Sticker Size- 4'0" X 3'0" = 12.0 Sq.ft. 1 Nos. = 1 X 12.0 = 12.0 Sq.ft.	Sq.ft.	12		
	<u>TYPE-D</u> Equipment Nomenclature by Retro Reflecting Sticker to be fixed on equipment body as per instruction of Engineer-in-charge.				
D(i)	Size- 1'6" X 1'6" = 2.25 Sq.ft. 24 Nos. = 24 X 2.25 = 54.0 Sq.ft.	Sq.ft.	54		

	<u>TYPE-E</u> Safety Slogan Board of ACP (3.0 MM/0.3 MM) with Vinyl print Sticker with S.S (Grade-304) Frame and provision for hanging from Street Light Tubular Pole & Structures.				
E(i)	Both Side Print Size- 1'6" X 2'0" = 3.0 Sq.ft. 60 Nos. = 60 X 3.0 = 180.0 Sq.ft.	Sq.ft.	180		
	<u>TYPE-F</u> Instruction Board of ACP (3.0 MM/0.3 MM) with Retro Reflecting Sticker with S.S (Grade-304) Frame and provision for structure/Gate mounting.				
F(i)	One Side Sticker Size- 3'0" X 10" = 2.5 Sq.ft. 10 Nos. = 10 X 2.5 = 25.0 Sq.ft.	Sq.ft.	25		
A	Sub-Total				
B	GST extra				
C	Grand Total				

(Rupees) Only

- NB:**
1. Price Schedule must be filled in complete shape.
 2. Tax extra will be paid as per prevailing norm of OPTCL
 3. All the materials to be supplied as per Technical Specification mentioned in Annexure-I of Section III.

(FULL SIGNATURE OF THE CONTRACTOR WITH SEAL)

ANNEXURE-III

Details of Sign Board with Dimensions

Type-A

Bay Identification/Direction Board - 78

Size	(i) 1' 0" X 1' 0" (W X H)- 73 (ii) 1' 0" X 1' 0" (W X H)- 04 (Both Side) (iii) 3' 0" X 1' 6" (W X H)- 01
Material	ACP with Retro reflecting Sticker
Frame	Stainless Steel (Grade-304) Square pipe of size ≥ 25 MM
Stand	Single Stainless Steel Tube of 900 MM Height of Dia 25 MM with provision for fixing in ground by concrete (1:2:4).

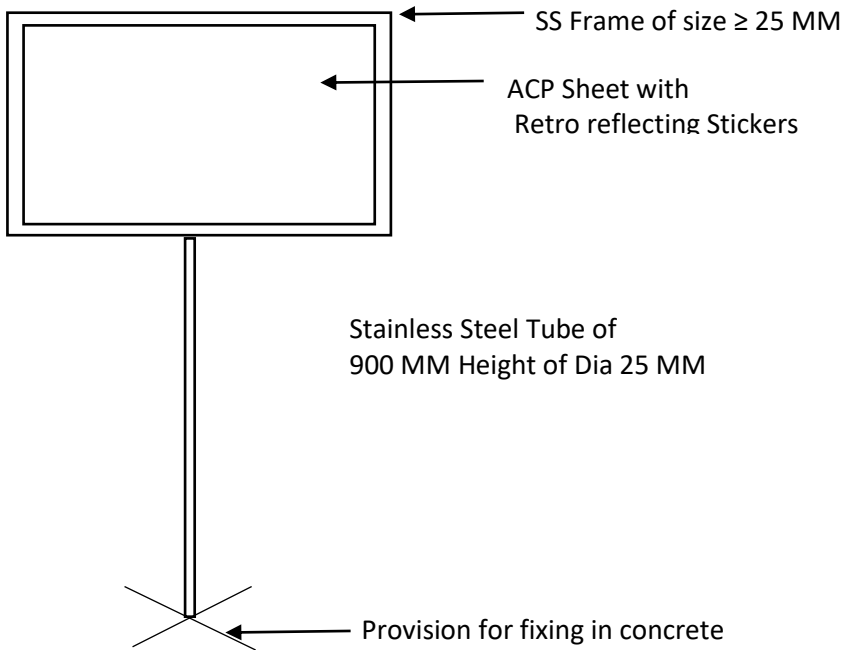

Type-B

Bay/Bus Identification/Safety Slogan Board

Size	(i) 1' 0" X 1' 0" (W X H) - 304
	(ii) 1' 6" X 2' 0" (W X H) - 10

Material ACP with Retro reflecting Sticker

Frame Stainless Steel (Grade-304) Square pipe of size ≥ 25 MM

Mounting To be Fixed on structures and Gate.

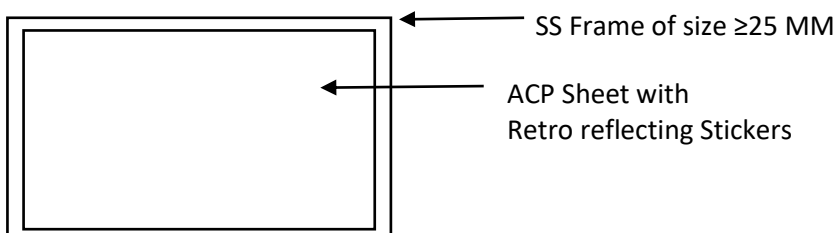

Type-C

Identification Board

- Size (i) 3' 0" X 1' 6" (W X H) - 03 Nos.
- (ii) 1' 6" X 1' 6" (W X H) - 12
- (iii) 4' 0" X 3' 0" (W X H) - 01

Material ACP with Retro reflecting Sticker

Frame Stainless Steel (Grade-304) Square pipe of size ≥ 38 MM

Stand Double Stainless Steel Tube of 900 MM Height of Dia ≥ 38 MM with provision for fixing in ground by concrete (1:2:4).

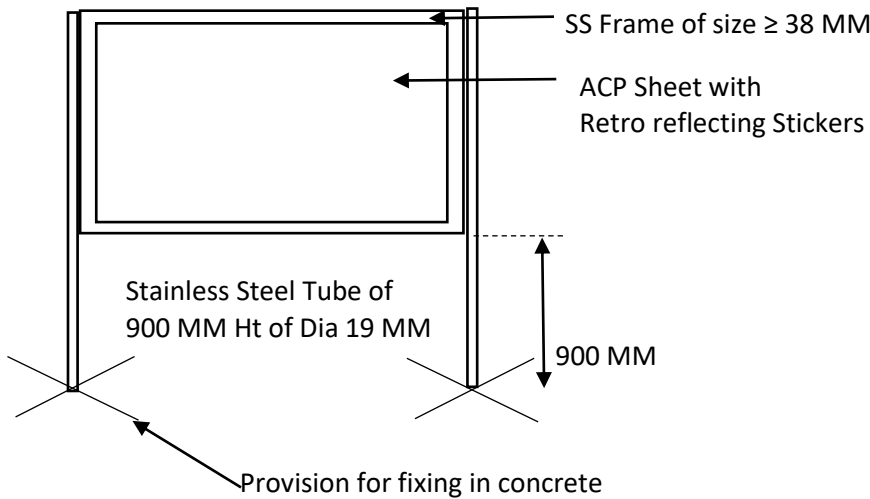

Type-D

Transformer Identification

Size 1' 6" X 1' 6" (W X H) - 24

Material Retro reflecting Sticker

Mounting To be fixed directly on equipment body

Type-E

Safety Slogan

Size 1' 6" X 2' 0" (W X H) - 60 (Both Side)

Material ACP with Laminated Vinyl Sticker

Frame Stainless Steel (Grade-304) Square pipe of size ≥ 25 MM

Stand Provision for hanging from street light tubular pole & Structures.

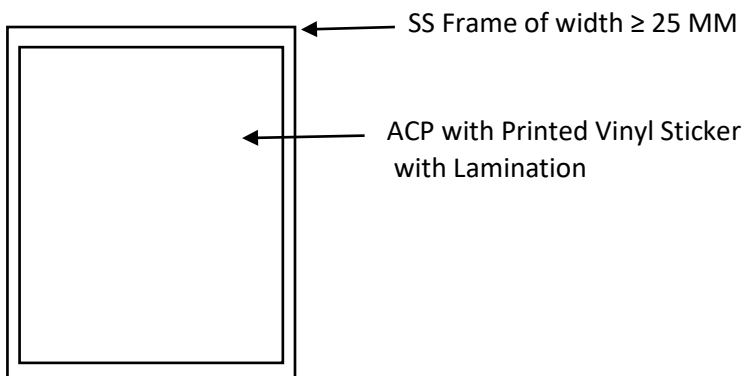

Type-F

Instruction Board

Size 3' 0" X 10" (W X H) - 10

Material ACP with Retro reflecting Sticker

Frame Stainless Steel (Grade-304) Square pipe of size ≥ 25 MM

Stand Provision for fixing on Gates

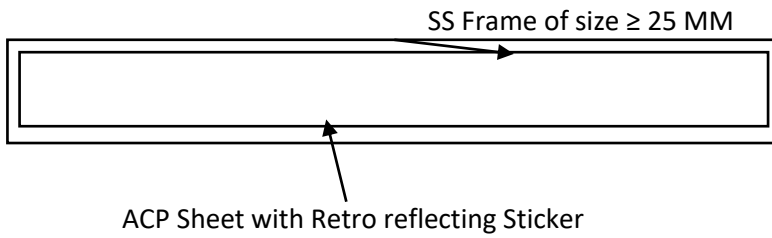

SECTION-IV
DECLARATION FORM
(TO BE SUBMITTED WITH THE TENDER PAPER)

To
The Dy.General Manager (El),
E.H.T. (O&M) Division
OPTCL, Meramundali

Sub: Tender Notice No.

Sir,

Having examined the above tender paper we hereby offer to Design, Supply and Installation of different types of Sign Board for 400/220/132 kV Grid S/S, Meramundali under EHT (O&M) Division, Meramundali, complete in all aspects to the rate/s entered as mentioned in our tender enclosed herewith.

1. We certify to have purchased a copy of tender paper remitting Rs.....by Cash/ Bank Draft and this has been acknowledged by you in your receipt No..... Dated.....

2. We enclosed herewith Rs. 5000.00 (Rupees Five Thousand only) as EMD in shape of Bank Draft/ Cash in favour of E.H.T. (O&M) Division, OPTCL, Meramundali payable at "STATE BANK OF INDIA", Bhushan Steel Plant, Narendrapur Branch.

Cash receipt/ Bank Draft No. Dt. .

3. We agree to the Security Deposit conditions if our bid will be considered for contract.

Yours faithfully,

Signature of Bidder
(with Seal)

THE BIDDERS ARE REQUIRED TO FURNISH THE FOLLOWING DETAILS AS PER THE FORMAT GIVEN BELOW WHICH IS A MANDATORY REQUIREMENT FOR EVALUATION OF BIDS

SL NO	DETAILS	TO BE FILLED BY THE BIDDER
1	BIDDER'S NAME	
2	BIDDER'S SITE NAME (NAME OF THE PLACE)	
3	ADDRESS	
4	CITY	
5	STATE	
6	COUNTRY	
7	PIN CODE	
8	PHONE NUMBER	
9	FAX NUMBER	
10	GST REGISTRATION NUMBER	
11	PAN NUMBER	
12	CONTACT PERSON'S NAME	
13	POSITION/DEPARTMENT OF CONTACT PERSON	
14	CONTACT PERSON'S E-MAIL ID	
15	CONTACT PERSON'S PHONE NO.AND MOBILE NO.	
16	CONTACT PERSON'S FAX NUMBER	

Signature of Bidder with Seal