



ODISHA POWER TRANSMISSION CORPORATION LIMITED

(A Govt. of Odisha undertaking)

CIN – U40102OR2004SGC007553

REGD. OFFICE: JANPATH, BHUBANESWAR-751022,

OFFICE OF THE DY. GENERAL MANAGER (Elect)

EHT (O&M) DIVISION, MERAMUNDALI

AT: KANTABANIA, P.O: KUSUPANGA,

DHENKANAL, ODISHA -759121

E-mail:-ehtm.div.mrm@optcl.co.in

TENDER SPECIFICATION FOR TENDER CALL NOTICE NO.01 /2020-21

**FOR CONSTRUCTION OF RCC SLABS & LAYING ON CABLE TRENCH INSIDE
400 KV SWITCHYARD AT 400/220/132/33KV GRID S/S, MERAMUNDALI**

COST OF TENDER PAPER

Rs. 4,000/- + 12% GST=Rs.4, 480/-

(Rupees Four Thousand Four Hundred Eighty only)

ISSUED TO

M/S

.....

.....

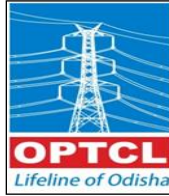

ODISHA POWER TRANSMISSION CORPORATION LTD
(A Govt. of Odisha undertaking)
CIN – U40102OR2004SGC007553
REGD. OFFICE: JANPATH, BHUBANESWAE-751022
OFFICE OF THE DY. GENERAL MANAGER (Elect)
EHT (O&M) DIVISION, MERAMUNDALI
AT: KANTABANIA, P.O: KUSUPANGA,
DHENKANAL, ODISHA -759121
E-mail: -ehtm.div.mrm@optcl.co.in

TENDER SPECIFICATION FOR TENDER CALL NOTICE NO.01/2020-21

**FOR CONSTRUCTION OF RCC SLAB & LAYING ON CABLE TRENCH INSIDE 400 KV S/Y
AT GRID S/S, MERAMUNDALI**

- | | |
|--|---|
| 1. SECTION-I | Tender Call Notice. |
| 2. SECTION-II | Instruction to Bidder. |
| 3. SECTION-III | General Terms & Condition of Contract |
| 4. SECTION-IV | TECHNICAL SPECIFICATION (WITH DRAWING) & PRICE SCHEDULE |
| 5. SECTION-V | (DECLARATION BY BIDDERS) |
| 6. Price of tender Document | Rs. 4000/-+12 % GST =Rs 4,480/-
(Rupees Four Thousand Four Hundred Eighty only). |
| 7. COMMENCEMENT OF SALE OF TENDER PAPER | 11.02.2021 (11AM to 5 P.M.) |
| 8. LAST DATE OF SALE OF TENDER PAPER | 26.02.2021 (Up to 1 P.M.) |
| 9. LAST DATE & TIME OF RECEIPT OF TENDER PAPER | 26.02.2021 (Up to 3P.M.) |
| 10. DATE & TIME OF OPENING OF TENDER | 26.02.2021 (at 3.30 P.M.) |

(SECTION-I)



ଓଡିଶା ବିଦ୍ୟୁତ ଶକ୍ତି ସଂଚାରଣ ନିଗମ ଲି.ଓ. ODISHA POWER TRANSMISSION CORPORATION LIMITED

(A Government of Odisha Undertaking)

Regd. Office: Janpath: Bhubaneswar-751022.

Telephone: (0674) 2540051 (EPABX), Website: www.optcl.co.in

CIN: U4102OR2004SGC007553

OFFICE OF THE DY. GENERAL MANAGER: ELECT.EHT (O & M) DIVISION, MERAMUNDALI

AT: KANTABANIA (400/220/132/33 KV GRID S/S), P.O: KUSUPANGA-759121, DIST: DHENKANAL (ODISHA)

Email: ehtm.div.mrm@optcl.co.in GSTN: 21AAAC07873I.176

NO.EHT (O&M)/MRM/TECH/66

Dt.10.02.2021

TENDER CALL NOTICE NO. 01/ 2020-21

The Dy. General Manager (Elect.), E.H.T. (O&M) Division, Meramundali invites sealed Tenders from intending Manufacturers/Authorized Dealers/Reputed Supplier for construction of RCC slab & laying on cable trench inside 400 kV S/Y at 400/220/132 kV Grid S/S, Meramundali under EHT (O&M) Division, Meramundali as follows.

Sl. No.	Description of work	Estimated Cost (Including 18% GST)	EMD	Cost of Tender specification paper	Documents required
1	Construction of RCC slab & laying on cable trench inside 400 kV S/Y at 400/220/132 kV Grid S/S, Meramundali	Rs 9,93,360/-	Rs. 10,000.00	Rs 4480/- (Rs4000/- +GST@12%)	Civil license (C or D), PAN, GST registration certificate (REG-06)

The tender specification can be obtained from the office of The DGM EHT (O&M) Division, MERAMUNDALI on payment of Rs. **4000/- (Four Thousand only) +GST @ 12%** (Non-Refundable) in shape of Cash/ Bank Draft in favor of DGM, EHT (O&M) Division, MERAMUNDALI payable at "STATE BANK OF INDIA", Bhushan Steel Plant, Narendrapur Branch on any working day from **Dt. 11.02.2021 to Dt. 26.02.2021 (up to 1:00 PM)**. In case the D.D made at any other nationalized bank payable at any clearing branch at Talcher/Angul will be allowed, but the bidders have to deposit the collection fee (Bank transaction fee) along with the paper cost. The collection fee & Paper cost is Non-refundable. Additional amount of Rs.100/- (One Hundred only) may be paid extra for postal delivery of the tender specification. The undersigned shall not be held responsible for any postal delay.

The Tender shall be received by **03.00 PM** on dated **Dt. 26.02.2021** & will be opened at **03.30 PM** on same day in the Office of the undersigned in the presence of the Bidders (or) their Authorized Representatives present if any. If any of the above date happens to be a holiday, the next working day will be the corresponding effective date. One Tender paper shall be issued to each Bidder. E.M.D of Rs. 10000.00 (Rupees Ten Thousand only) should be deposited in shape of Cash /Demand Draft in favour of **E.H.T. (O&M) Division, Meramundali & payable at "STATE BANK OF INDIA", Bhushan Steel Plant, Narendrapur Branch.**

The Bidder should super scribe only the "Tender Call Notice No. & Date of Opening of the tender on the body of the Sealed Envelope". Bidder should not write their name or any other information on the body of the sealed envelope. Superscribing any other information on the body of the envelope, Conditional tender, Incomplete tender, Telegraphic / Fax / E-mail (etc.) Tenders & Tenders not accompanied with requisite amount of E.M.D. will be rejected. The authority reserves all rights to reject any, all or part of the Tender, alter/modify the requirement/ delete any part of the tender without assigning any reason thereof. N.B:- Tender Paper must be purchased from this office only. No other mode like downloaded paper from website will be accepted.

General Manager (Elect.)
EHT (O&M) Division, Meramundali

(SECTION-II)
INSTRUCTION TO TENDERERS

1. Sealed tender duly super scribed as “**TENDER AGAINST TENDER NOTICE No. 01/2020-21** are invited from experienced contractors with civil contractor license (C or D) issued by Govt. of Odisha /Govt. Of India railways/ Military for the work construction of RCC slab & laying on cable trench inside 400 kV S/Y at Grid S/S, Meramundali as per the technical specification enclosed to be received in this office on or before 3.00 P.M. **Dt. 26.02.2021** and the same shall be opened on **Dt. 26.02.2021** at 3.30 PM in presence of the Tenderers or their authorized agents if any. Tenders received after 3.00 P.M. on **Dt. 26.02.2021** will not be accepted, since the tender box will be closed at 3.00 P.M.
2. Tender shall be submitted duly signed in each page by the authorized signatory in a sealed cover envelope addressed to the Dy. General Manager, EHT (O&M) Division, Meramundali, At-Kantabania, Po- Kusupanga, Dhenkanal-759121. All the documents submitted along with the tender must be signed and certified by the authorized signatory of the bidder.
3. No telegraphic tenders/forwarding by FAX will be accepted.
4. This office will not be responsible for non-receipt/late receipt of the tender documents due to postal delay.
5. The tenders shall be furnished strictly as per the terms and conditions of the tender specification. Incomplete tenders will be rejected.
6. The Authority may alter the quantum of work at the time of placing orders. Orders may also be split up among more than one tenderer depending upon necessity & urgency.
7. Only those, who have purchased the tender specification from this office by their name/Firm’s name, can submit their tender. Tenders submitted by others will be rejected.
8. Tenders will be submitted in person/by registered post with A.D. Tenders submitted by any other means shall not be accepted. Postal delay shall not be considered. Tenders received after due date and time shall be returned un-opened.
9. (i) The tender shall be accompanied with **earnest money** of Rs. 10000.00 (Rupees Ten Thousand only) in shape of Cash/Bank Draft drawn in favor of the, **EHT (O&M) Division, OPTCL, Meramundali**, Payable at "STATE BANK OF INDIA", Bhushan Steel Plant, Narendrapur Branch without which their tender shall be rejected. Cheques will not be accepted.
(ii) No interest shall be paid on E.M.D.
10. The authority reserves the right to reject the lowest or any other tender or all tender without assigning any reason what-so-ever.
11. Offers should be neatly typed without any overwriting and corrections.
12. In the event of discrepancy or arithmetical error in the bid, the decision of the purchaser shall be final and binding on the tenderer.
13. For evaluation, the price mentioned in words shall be taken, if there is any difference in figure and words in the price bid.
14. Conditional tender shall not be accepted and no discount other than the quoted price will be allowed as mentioned in the original offer.
15. **The tenderers are advised to visit the site and make them acquainted with the site condition before submission of tender.**

GENERAL MANAGER (Elect.)
EHT (O&M) DIVISION, MERAMUNDALI

(SECTION-III)
GENERAL TERMS & CONDITIONS OF CONTRACT

Sealed tenders are invited in duplicate from intending Bidders having valid CIVIL Contract License with PAN and GST Registration for construction of RCC slab & laying on cable trench inside 400 kV S/Y at 400/220/132 kV Grid S/S, Meramundali under EHT (O&M) Division, Meramundali.

1. SUBMISSION & OPENING OF TENDER: - Tender shall be submitted with other documents in duly sealed envelope super scribed on the body of envelope "Tender for construction of RCC slab & laying on cable trench inside 400 kV S/Y at 400/220/132 kV Grid S/S, Meramundali". The bidder should write only Tender Specification No, the name of work and date of opening of the tender on the body of the sealed envelope. Bidder should not write their name or Agency name on the body of the sealed envelope which may make the offer liable for rejection.

2. RIGHT & AUTHORITY FOR REJECTION: - Tenders received after due date and time will be summarily rejected. The General Manager (Electrical), E.H.T. (O&M) Division, Meramundali reserves the right to reject any or all of the tenders without assigning any reason thereof.

3. VALIDITY OF OFFER: - The offer should be firm and valid for a period of at least 120 days from the date of opening of tenders. Unless the tender will be rejected.

4. EARNEST MONEY DEPOSIT:- The tender should be accompanied with Rs. 10,000.00 (Rupees Ten Thousand only) towards Earnest Money Deposit (EMD) in shape of **Cash/ Bank Draft** in favour of **EHT (O&M) Division, OPTCL, Meramundali**, Payable at "STATE BANK OF INDIA", Bhushan Steel Plant, Narendrapur Branch otherwise tender will be out rightly rejected. In case the B.D made any other nationalized bank payable at any clearing branch at Talcher/Angul will be allowed, but the bidders have to deposit the collection fee (Bank transaction fee) along with the EMD. The collection fee is Non-refundable & It can't be taken into account of EMD deposit. The EMD of the unsuccessful bidders will be returned after finalization of tender. The EMD of the successful bidders will be returned only after the Security money deposited as per the clause No. (6) in Section (III). In case of successful bidder fails to execute the order satisfying all terms & conditions or also fails to commencement of work within stipulated date mentioned in the date of order, the Earnest Money Deposit will be forfeited. No interest will be paid on the EMD to any participator. No other mode than above for EMD Deposit will be accepted & bidder will be out rightly rejected.

5. PRICE:- The bidders are advised to quote their rate as per the price schedule in Section-V with break up prices including of all Taxes & Duties and shall remain up to the validity of tenders.

6. SECURITY DEPOSIT: - The bidders whose offer qualifies for acceptance will be awarded work order for execution of the works and the bidder shall have to deposit security amount equal to 10% (ten percent) of contract value in shape of cash/bank draft drawn in favour of respective paying officer, of OPTCL, The security deposit shall be released after two months of the guarantee period as stated under clause-10 of SECTION-III on receipt of application for this purpose. No Interest shall be paid to the bidder towards the security deposit so deposited by the Bidder. The security deposit shall be deposited with the respective paying officer of OPTCL prior to commencement of work. The security deposit shall be released after expire of Guarantee period. In case of Non-fulfilment of contractual obligation by the supplier, the same so deposited shall be forfeited.

7. COMMENCEMENT & COMPLETION OF WORK: - The works awarded should be commenced from 15 days of the award of the contract and completed within 60 days. If the work could not be

completed within scheduled date due to any valid reason, then completion period may be extended on written request by the Bidder. If the work will not commence & complete within the stipulated period, then the penalty should be imposed as per clause No.08 of SECTION-III.

8. PENALTY: - Penalty @ ½%(half per cent) per week up to a maximum of 5% of the total value of the work order will be imposed and recovered from dues admissible if the work will not completed within the specified date in SECTION –III, clause-7. However imposition of penalty clause is subject to force majeure condition.

9. TERMS OF PAYMENT: - 100 % (one hundred percent) payment along-with full taxes and duties (if any) shall be made after successful completion of the work in all respect and verification reports thereof by respective consignee and Paying Officer and on receipt of funds from Head Office in this regard. After complete execution of work, the bidder shall produce the printed bills to the respective consignee/Paying Officer for effecting payment. No part payment or running bill is allowed without completion of work in all respect.

10. GUARANTEE PERIOD: - The work done by the contractor as per contract specification should be guaranteed for satisfactory operation and against any defects, in materials & the workmanship for a period of 18 months from the date of completion of the work or 12 months from the date on which material has been put to service, whichever is earlier. The above guarantee certificate shall be furnished in triplicate to the undersigned for approval. Any defects noticed during the period shall be rectified by the contractors at its own cost, without any financial burden to OPTCL.

11. DOCUMENTS: - The following Xerox copy should be submitted with the tender paper & the same will be verified with original documents at the time of opening of tender.

- i) **Civil Contract License (class C & D)**
- ii) GST Registration Certificate.
- iii) Valid PAN/ TIN.
- iv) Experience Certificate (optional)

12. ADDITION OR DELETION OF CONTRACT: - The Contract may be altered in quantum as per exigencies of work. The bidder shall accordingly provide services as may be required by the Officer- in - Charge on being given a notice of 15 days

13. ARBITRATION: - In the event of any dispute arising out his contract. The same shall be referred for arbitration to the Director (HRD) OPTCL, Bhubaneswar or any arbitrator appointed by the Managing Director, OPTCL after due notice of claim and such appointment and the award of the arbitrator shall be final and binding arbitration and conciliation Act. 1996 shall apply. The venue of arbitration will be Bhubaneswar.

14. CONSIGNEE: - The AGM/Manager, 400/220/132 kV Grid S/S, Meramundali is the consignee for the contract.

15. PAYING OFFICER: - The DGM, EHT (O&M) Division, Meramundali is the paying Officer for contract.

16. JURISDICTION OF COURT: - Suits if any, arising against the work order to be issued to the Bidder shall be filled by either party in any court of law to which the jurisdiction of Odisha High Court extends.

17. **SAFETY PRACTICE:** - The Bidder must be followed the OPTCL safety Rule while performing the work. The workmen must be provided with Safety equipment by the contractor while performing the works .No deviation will be allowed and the consignee has got any power to stop the work at any time on the breach of safety practice.
18. **OUTRIGHT REJECTION OF TENDERS:** - The tenders shall be liable for outright rejection if the following have not been complied.
- a) Tenderers should have purchased the tender specification from the office of the D.G.M., EHT (O&M) Division, Meramundali-759121 in his own or Firm's name.
 - b) Tenders shall be submitted in person or by Registered post with A.D. and received before the time fixed for receipt of tender.
 - c) Tenders shall not be submitted telegraphically or by FAX.
 - d) Tenders shall be accompanied with the prescribed earnest money deposit.
 - e) Tenders shall be kept valid for a minimum of 120 days from the date of opening of the tender.
 - f) Tenders shall be accompanied with clear valid attested Xerox copy of PAN No., ITCC as well as Civil contractor's license which must be valid on the date of opening of the tender. All copies of documents and each page of the tender must be signed by the authorized representative of the bidders.
 - g) The contractor agreed to obtain Labour Contract License on event of work order from the competent authority.
 - h) The tender shall not be conditional.
 - i) The tenderers shall fill the information at Annexure-II of this tender specification.
 - j) The tenderer shall agree to all other terms and conditions of the tender specification.

**GENERAL MANAGER (Elect.)
EHT (O&M) DIVISION, MERAMUNDALI**

(SECTION-IV)
TECHNICAL SPECIFICATION (WITH DRAWING) & PRICE SCHEDULE

TECHNICAL SPECIFICATION (With Drawing)

The Scope of work: - The scope of works must covers the followings & as per Drawing.

- i) Specification of RCC Slab mentioned in Table and all other dimensions are as per drawing mentioned below.
- ii) Steel having IS-1786 shall be used of any reputed brand which are established, reliable, indigenious and primary producer of steel having integrated steel plant (ISP), using iron ore as basic raw materials as per ministry of steels guideline. No re rolled steel shall be permitted in work.
- iii) 53 grade cement shall be used of any reputed manufacturers of cement inside the state.
- iv) Pond watering shall be provided for RCC work as per the instruction of site in-charge. The contractor has to arrange adequate supply of clean water required for the work whenever necessary at his/her own cost.
- v) The successful bidder shall make his own arrangement for all materials and T&Ps such as concrete mixture, vibrator, PRR etc. for the work.
- vi) The quoted rate for the work will deem to include all incidental items which may necessary for construction of benchmarks, level pillars, profiles, benching levels of the ground etc. where required. No extra payment or claim will be admissible on this ground.
- vii) Cleaning of debris where necessary shall be considering as incidental to the work and shall be contractor's responsibility to clean it.

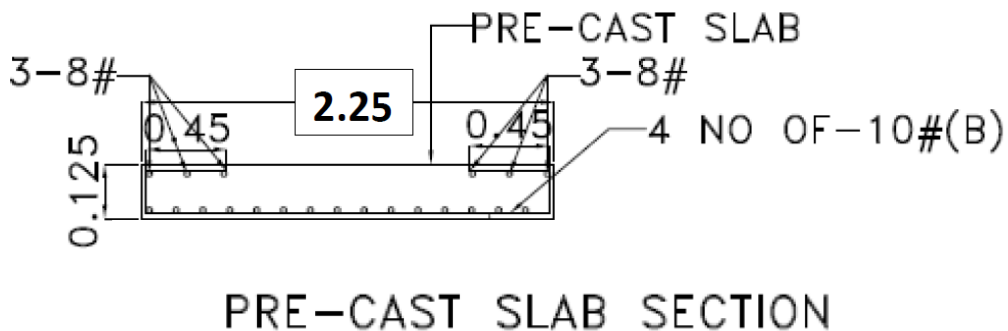
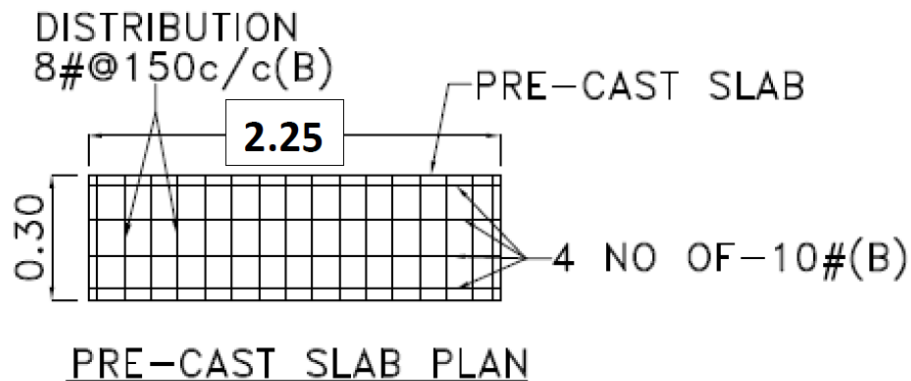

PRICE SCHEDULE

Construction of RCC slab & laying on cable trench inside 400 kV S/Y at Grid S/S, Meramundali.					
SL.No	Name of works	Unit	Qty.	Rate	Amount
1	Reinforcement :- Supply of all materials , good quality planks ,ballas, shuttering plates for centring, shuttering, supply of good quality 20mm machine broken granite chips , good quality river sand & concreting , curing for cable trench slab as per IS:4156 including cost of taxes royalties lead lift , labour and T & P with cost of cement & without steel . As per above specification and ration of concrete (1:1.5:3) with cost of cement & without steel.	Cum	54.844		
2	Cutting ,bending ,binding placing in position of steel rods for slab concreting including cost of binding wires with supply of all size rods(TATA/RINL/SAIL make)	Cum	68.471		
3	Rigid smooth centring and shuttering for RCC works including false work and dismantling then after casting etc. Plinth band, foundation and footing, base of column, mass concrete etc.	Sqm	414.38		
				Add GST @ 18%	
				Grand Total	

(Rupees.....) only

- NB:**
- 1. Price Schedule must be filled in complete shape.**
 - 2. Tax extra will be paid as per prevailing norm of OPTCL**

Dated

SIGNATURE OF THE TENDERER WITH SEAL

(SECTION-V)
DECLARATION BY THE BIDDER

(To be furnished by the Tenderer)

- | | | | |
|------|---|-----|--|
| 1. | Name of the work | : - | Construction of RCC slab & laying on cable trench inside 400 kV S/Y at Grid S/S, Meramundali. |
| 2. | Name of the Contractor & address | : - | |
| 3. | Earnest Money deposit Details | : - | |
| 4. | Attested copy of Pan Card | : - | Furnished/Not furnished |
| 5(i) | Attested copy of valid Civil Contractor License | : - | Furnished/Not furnished |
| (ii) | Attested copy of Goods & Service Tax registration Certificate as applicable | : - | Yes/No |
| 6. | Agreed to furnish security Deposit-Cum-Performance guarantee as per terms of tender. | : - | Yes/No |
| 7. | Agreed to adhere completion of work as per the contract | : - | Yes/No |
| 8. | Agreed to accept payment terms as per the tender. | : - | Yes/No |
| 9. | Agreed to accept penalty clause as per the tender. | : - | Yes/No |
| 10. | Attach past experience certificate: - for the similar job in OSEB/ Gridco or any other Agencies. | : - | Yes/No |
| 11. | Agreed to keep validity of the tender for 120 days from the date of opening of tender without any variation in the tender clause. | : - | Yes/No |
| 12. | Agreed to obtain labour contract: - license on event of work order from the competent authority. | : - | Yes/No |
| 13. | Submitted tender in duplicate | : - | Yes/No |
| 14. | Agreed to all terms & conditions: - of the tender specifications | : - | Yes/No |

Date: -

SIGNATURE OF TENDERER
WITH SEAL